



Accessibility Requirements and Readily Achievable Barrier Removal for Historic Buildings and Facilities

Based on the Fifth Edition (2014) Florida Accessibility Code for Building Construction



Table of Contents

Introduction.....	2
National Park Service / Secretary of the Interior’s Standards regarding handicapped accessibility.....	3
FACBC Requirements for Historic Buildings and Facilities with Public Accommodations.....	5
Readily Achievable Barrier Removal for Historic Buildings and Facilities.....	8
2012 Florida Accessibility Code Requirements (relevant to Historic Buildings and Facilities).....	9
How to Use the ADA Checklist.....	20
Additional Resources and References.....	22
Contacts for Additional Information.....	23

ADA Checklist for Readily Achievable Barrier Removal Priority 1 – Approach and Entrance

ADA Checklist for Readily Achievable Barrier Removal Priority 2 – Access to Goods and Services

ADA Checklist for Readily Achievable Barrier Removal Priority 3 – Toilet Rooms

ADA Checklist for Readily Achievable Barrier Removal Priority 4 – Additional Access

Produced by the Florida Department of State Division of Historical Resources, Bureau of Historic Preservation
Architectural Preservation Services Section

Kenneth H. Cureton, RA, NCARB
Richard L. Hilburn, RA

Rev 09/2015

What this document is

Historic Buildings have unique challenges when it comes to accommodating public use that encompasses all segments of the population, as well as functioning consistent with current standards of the built environment. Very few historic buildings were constructed to any unified code, and even fewer took handicapped accessibility issues into account. Thus, the majority of historic buildings that are still in service require various levels of modification for continued access by the public, and the goal is to do so in a manner that allows the building to retain its historical integrity.

The purpose of this document is threefold:

1. To provide Owners and Managers of historic buildings and facilities an evaluation tool to determine baseline compliance of public accommodations with the Florida Accessibility Code for Building Construction;
2. To facilitate the first step in a priority-based planning process for *readily achievable* barrier removal; and
3. To provide guidance for planning that addresses the Secretary of the Interior's Standards for Rehabilitation (as based on Chapter 12 of the 2014 Florida Building Code – Existing Building).

What this document is not

This document is not intended to constitute a formal code compliance review necessary to assure public health, safety and welfare. The scope of this document is for handicapped accessibility guidance purposes only, and does not represent all aspects of the code. With the exception of minor corrections for accessibility, users of this document are advised to consult a licensed design professional for a full code compliance evaluation prior to conducting any type of modifications to a structure in which a building permit may be required.

The user should be aware that the ADA Title III regulations require more than barrier removal. The regulations include requirements for nondiscriminatory policies and practices and for the provision of auxiliary aids and services, such as sign language interpreters for people who are deaf and material in Braille for people who are blind. This document does not cover those requirements, nor is it intended to be the sole source for determination of accessibility compliance of new construction or existing facilities being altered.

National Park Service / Secretary of the Interior's Standards for Rehabilitation of Historic Properties regarding handicapped accessibility

All preservation, rehabilitation, restoration and reconstruction work to a *Qualified Historic Building or Facility* is governed by the Secretary of the Interior's Standards for Rehabilitation of Historic Buildings (the *Standards*), and have been adopted by reference into Chapter 12 and Appendix B of the Florida Building Code – Existing Building. Accordingly, the following guidance from the National Park Service (NPS) on the subject of handicapped accessibility of historic buildings has been provided.

Accessibility to certain historic structures is required by three specific federal laws: the Architectural Barriers Act of 1968, Section 504 of the Rehabilitation Act of 1973, and the Americans with Disabilities Act of 1990. Federal rules, regulations, and standards have been developed which provide guidance on how to accomplish access in historic areas for people with disabilities. Work must be carefully planned and undertaken so it does not result in the loss of character-defining spaces, features, and finishes. The goal is to provide the highest level of access with the lowest level of impact.

Although retrofitting for handicapped accessibility is quite often an important aspect of rehabilitation projects, it is usually not part of the overall process of preserving character-defining features (identify, protect, repair, replace); rather, such work is assessed for its potential negative impact on the building's historic character. For this reason, particular care must be taken not to obscure, radically change, damage, or destroy character-defining features in the process of rehabilitation work to meet accessibility requirements.

Activities recommended include:

- Identifying the historic building's character defining spaces, features, and finishes so that accessibility code-required work will not result in their damage or loss
- Complying with barrier-free access requirements, in such a manner that character defining spaces, features, and finishes are preserved
- Working with local disability groups, access specialists, and historic preservation specialists to determine the most appropriate solution to access problems
- Providing barrier-free access that promotes independence for the disabled person to the highest degree practicable, while preserving significant historic features
- Designing new or additional means of access that are compatible with the historic building and its setting

Activities not recommended include:

- Undertaking code-required alteration before identifying those spaces, features or finishes which are character-defining and must therefore be preserved
- Altering, damaging, or destroying character-defining features in attempting to comply with accessibility requirements
- Making changes to buildings without first seeking expert advice from access specialists and historic preservationists, to determine solutions
- Making access modifications that do not provide a reasonable balance between independent, safe access and preservation of historic features
- Designing new or additional means of access without considering the impact on the historic property and its setting

The user should be aware that there are two sets of codes that must be satisfied simultaneously in order to provide handicapped access to a *Qualified Historic Building or Facility* – The 2014 Florida Accessibility Code for Building Construction (**FACBC**) and the Florida Building Code – Existing Building, Chapter 12 (**FBC-EB**). The user is strongly advised to incorporate the preceding NPS guidance for compliance with the *Standards* in order to successfully satisfy requirements of both codes.

Further technical guidance from the National Park Service regarding handicapped accessibility for historic buildings and structures can be found at the following:

National Park Service Technical Preservation Services Preservation Brief No. 32 – Making Historic Properties Accessible
[nps.gov/tps/how-to-preserve/briefs/32-accessibility.htm](https://www.nps.gov/tps/how-to-preserve/briefs/32-accessibility.htm)

National Park Service Technical Preservation Services ITS Brief No. 53 – Designing New Additions to Provide Accessibility
[nps.gov/tps/standards/applying-rehabilitation/its-bulletins/ITS53-Additions-Accessibility.pdf](https://www.nps.gov/tps/standards/applying-rehabilitation/its-bulletins/ITS53-Additions-Accessibility.pdf)

FACBC Requirements for Historic Buildings and Facilities with Public Accommodations

Scope of Accessibility Requirements. All areas of new *additions* to and *altered* portions of historic buildings and facilities housing public accommodations or commercial functions, whether publicly or privately owned, shall comply with the 2014 Florida Accessibility Code for Building Construction (**FACBC**) and the Americans with Disabilities Act (**ADA**) requirements. Public entities (State and Local Governments) operating in historic buildings or facilities shall conduct services, programs, or activities that are readily *accessible*, but are not required to make structural changes to historic buildings or facilities where other methods are effective in achieving compliance. (See FACBC Section 201.1).

When are modifications for accessibility to historic buildings and facilities required? The FACBC requirement to conduct modifications for handicapped accessibility to a historic building or *facility* that houses public accommodations or commercial functions is limited to whenever:

- Renovations or *alterations* are undertaken;
- A change in use or occupancy classification of the building is made from residential to non-residential or mixed use; and
- In cases where the original construction or subsequent work was conducted in violation of an applicable permitting law.

The FACBC does not require that work be performed to existing buildings solely for ADA compliance without first being triggered by one of the three conditions listed above, but owners of public accommodations and commercial facilities are required by Federal Law Title III 28 CFR 36.304 to remove architectural and structural communications barriers to the *maximum extent feasible* to allow for non-discrimination on the basis of a disability. Failing to comply with Federal barrier removal requirements will expose the owner to potential legal action from users, so at a minimum owners are advised by the Department of Justice to develop an implementation plan for barrier removal and execute the plan at the earliest possible time. Such a plan would serve as evidence of a good faith effort for compliance with ADA requirements for accessibility.

Exceptions to accessibility requirements for Historic Buildings and Facilities. In cases where the State Historic Preservation Officer (SHPO) determines that *alterations* required to achieve compliance with ADA standards of accessibility would threaten or destroy the historic significance of a building, exceptions to accessibility requirements indicated in FACBC Section 202.5 related to *accessible routes*, *entrances* and toilet facilities are permitted to apply. General exceptions to accessibility requirements (Section 203), *technical feasibility* (Sections 106.5 and 202.3), and *disproportionate costs* (202.4.1) are exceptions that may apply as indicated in the FACBC.

Historic Preservation Program Alternative Compliance. Where public entities are providing *alterations* for access to qualified historic buildings or facilities that operate *historic preservation programs*, priority shall be given to methods of compliance that provide physical access to individuals with disabilities. When *alterations* to a historic building or *facility* would result in destruction of historic significance, fundamental alteration of the program, undue financial or administrative burdens, alternative methods of compliance are permitted as listed in Federal Law Title III 28 CFR 35.150 (b)(3) that would provide a minimal level of access.

Alterations. All *alterations* to Qualified Historic Buildings and Facilities (listed or eligible to be listed in the National Register of Historic Places, or otherwise designated by law) are required to comply with Section 202.5 of the FACBC to the maximum extent feasible. The FACBC applies to the existing elements, spaces and common areas of historic buildings and facilities that are within the scope of work for any *alterations*. (See FACBC Section 202.3)

Per FACBC Section 202.4, in cases where *alterations* are made to Primary Function areas of a historic building or *facility*, the scope of work shall include, to the maximum extent feasible, an accessible path of travel to the altered area from the building or *facility* entrance, and shall include accessibility upgrades to rest rooms, telephones, and drinking fountains serving the altered area.

If costs of *alterations* for the accessible *path of travel* are disproportionate, full compliance is not required, but the following prioritized elements shall be made accessible to the greatest extent possible without incurring disproportionate costs:

1. an *accessible entrance*;
2. an *accessible* route to the altered area;
3. at least one *accessible* restroom for each sex or a single unisex restroom;
4. *accessible* telephones;
5. *accessible* drinking fountains; and
6. additional *accessible* elements such as parking, storage, and alarms.

Additions. Where new *additions* to historic buildings or facilities are planned, all areas of each *addition* shall comply with the FACBC requirements for new construction. (See FACBC Section 202.2)

Change of Occupancy. The Florida Existing Building Code Section 1012.8 requires that historic buildings that are being converted from residential to nonresidential or mixed use comply with the FACBC. The exceptions to compliance previously listed may apply to a change of occupancy.

Commercial Facilities and Places of Public Accommodation located in historic private residences.

When a commercial *facility* or place of public accommodation is located in a private residence (e.g. a Bed and Breakfast), the residential portion used exclusively for owner occupancy is not regulated by the FACBC. The portion used either incidentally or exclusively in the operation of the commercial *facility* must meet the new construction and *alterations* requirements of the FACBC. Such portions extend to those elements used to enter the commercial *facility*, including the homeowner's front sidewalk, the entryway, hallways and those portions of the residence, interior or exterior, available to or used by employees, visitors, customers or clients of the commercial *facility*, including restrooms. (See FACBC Section 201.2.1).

Vertical Accessibility. In Florida, no code or standard relieves the owner of any historic *building* or *facility* from the duty to provide vertical accessibility to all levels above and below the occupiable grade level (with certain exceptions indicated in the FACBC). Where the ADA Standards do not require an accessible route to each and every level, the Florida requirement for vertical accessibility may be waived down to, but not below, the requirements of the ADA Standards. Exceptions to vertical accessibility requirements may be allowed by SHPO determination, *disproportionate costs*, technical infeasibility or general exceptions indicated in Sections 201.1.1 and 203 of the FACBC. Accessibility Waivers may be obtained from the Florida Building Commission through the Accessibility Waiver process.

Remedial Work. Remedial work performed on historic buildings and facilities for compliance with FACBC requirements shall be performed according to the Florida Building Code – Existing Building and the Secretary of the Interior's Standards for Rehabilitation.

Items Contributing to Accessibility Requirements. In addition to the FACBC, referenced statutes and regulations that contribute to accessibility requirements of historic buildings and facilities include Sections 553.501-553.513 F.S., Title 28 CFR Parts 35.150, 35.151, 36.304, 36.305 and ADA Standards for Accessible Design.

Readily Achievable Barrier Removal for Historic Buildings and Facilities

Architectural and Structural Communication barriers are defined as physical elements of a building or *facility* that impede access by people with disabilities. Architectural barriers may include change in floor level, improper mounting heights and operation types of controls and dispensers, hazardous floor surfaces and inadequate maneuvering space for wheelchairs around walls, equipment and furnishings. Structural Communication barriers include inadequate or inaccessible signage, alarms and communication devices that do not serve both the visually and hearing impaired, physical partitions that block sound between employees and customers, etc. Federal Law Title III 28 CFR 36.304 mandates that such barriers shall be removed from historic buildings and facilities that house public accommodations or commercial functions, whether publicly or privately owned, where such removal is readily achievable. Barrier removal would not be considered readily achievable if it would threaten or destroy the historic significance of a Qualified Historic Building or Facility.

Examples of *readily achievable* barrier removal include, but are not limited to:

- Installing ramps
- Making curb cuts in sidewalks
- Installing flashing alarm lights
- Repositioning shelves
- Repositioning telephones
- Adding raised markings on controls
- Rearranging furniture and equipment
- Widening doors
- Installing offset hinges to widen doorways
- Removing high pile, low density carpeting
- Installing accessible door hardware
- Installing grab bars in toilet stalls or rooms
- Rearranging toilet partitions
- Providing an alternative accessible path
- Installing a raised toilet seat
- Installing a full-length bathroom mirror
- Installing vehicle hand controls
- Creating designated accessible parking
- Repositioning the paper towel dispenser
- Insulating lavatory pipes under sinks
- Installing accessible paper cup dispensers

Where barrier removal is not *readily achievable*, other measures that may not fully comply with the specified ADA requirements or reasonable alternatives for public access are allowed and shall be provided.

Priorities for Barrier Removal. The ADA Title III regulations recommend four priorities for barrier removal as follows:

Priority 1 - Accessible approach from sidewalks and parking areas to an accessible *entrance* to the *facility*

Priority 2 - Access to goods and services that are made available to the public

Priority 3 - Access to public toilet rooms

Priority 4 - Access to other items such as water fountains and public telephones

Note: Public accommodations may determine the most effective mix of barrier removal measures to undertake in their facilities.

2012 Florida Accessibility Code Requirements

Selected Sections Relevant to Qualified Historic Buildings and Facilities

106 Definitions (selected items for existing buildings)

106.5 Defined Terms.

Accessible. A site, *building*, *facility*, or portion thereof that complies with the current Florida Accessibility Code.

Addition. An expansion, extension, or increase in the gross floor area or height of a *building* or *facility*.

Alteration. A change to a *building* or *facility* that affects or could affect the usability of the *building* or *facility* or portion thereof. *Alterations* include, but are not limited to, remodeling, renovation, rehabilitation, reconstruction, historic restoration, resurfacing of circulation paths or vehicular ways, changes or rearrangement of the structural parts or elements, and changes or rearrangement in the plan configuration of walls and full-height partitions. Normal maintenance, reroofing, painting or wallpapering, asbestos removal, or changes to mechanical and electrical systems are not *alterations* unless they affect the usability of the *building* or *facility*. *Refer to the Florida Building Code - Existing Building for specific *Alterations* definitions and requirements.

Building. Any structure used or intended for supporting or sheltering any use or occupancy.

Circulation Path. An exterior or interior way of passage provided for pedestrian travel, including but not limited to, walks, hallways, courtyards, elevators, platform lifts, *ramps*, stairways, and landings.

Disproportionate Costs. Costs that exceed 20% of the overall cost of the alteration to the *Primary Function* area (see section 202.4)

Entrance. Any access point to a *building* or portion of a *building* or *facility* used for the purpose of entering. An *entrance* includes the approach walk, the vertical access leading to the *entrance* platform, the *entrance* platform itself, vestibule if provided, the entry door or gate, and the hardware of the entry door or gate.

Facility. All or any portion of *buildings*, structures, site improvements, elements, and pedestrian routes or vehicular ways located on a site.

Historic preservation programs. Programs conducted by a public entity that have preservation of *historic properties* as a primary purpose.

Historic Properties. Those properties that are listed or eligible for listing in the National Register of Historic Places or properties designated as historic under State or local law.

Maximum Extent Feasible. The phrase "to the *maximum extent feasible*," as used in this code, applies to the case where the nature of an existing *facility* makes it virtually impossible to comply fully with applicable accessibility standards through a planned *alteration*. In these circumstances, the *alteration* shall provide the maximum physical accessibility feasible. Any altered features of the *facility* that can be made *accessible* shall be made *accessible*. If providing accessibility in conformance with this section to individuals with certain disabilities (e.g., those who use wheelchairs) would not be feasible, the *facility* shall be made *accessible* to persons with other types of disabilities (e.g., those who use crutches, those who have impaired vision or hearing, or those who have other impairments). ***SEE SECTION 202.5 - Alterations to Qualified Historic Buildings and Facilities for application.**

Path of Travel. Defined as one or more of the following:

1. A *path of travel* includes a continuous, unobstructed way of pedestrian passage by means of which the altered area may be approached, entered, and exited, and which connects the altered area with an exterior approach (including sidewalks, streets, and parking areas), an *entrance* to the *facility*, and other parts of the *facility*.
2. An *accessible path of travel* may consist of walks and sidewalks, curb ramps and other interior or exterior pedestrian ramps; clear floor paths through lobbies, corridors, rooms, and other improved areas; parking access aisles; elevators and lifts; or a combination of these elements.
3. For the purposes of this code, the term *path of travel* also includes the restrooms, telephones, and drinking fountains serving the altered area.

Primary Function. A major activity for which the *facility* is intended. Areas that contain a *primary function* include, but are not limited to, the customer services lobby of a bank, the dining area of a cafeteria, the meeting rooms in a conference center, as well as offices and other work areas in which the activities of the *public entity*, *public accommodation* or other private entity using the *facility* are carried out. Mechanical rooms, boiler rooms, supply storage rooms, employee lounges or locker rooms, janitorial closets, *entrances*, and corridors are not areas containing a *primary function*. Restrooms are not areas containing a *primary function* unless the provision of restrooms is a primary purpose of the area, e.g., in highway rest stops. Areas of transportation *facilities* that involve *primary functions* include, but are not necessarily limited to, ticket purchase and collection areas and passenger waiting areas.

Qualified Historic Building or Facility. A *building* or *facility* that is listed in or eligible for listing in the National Register of Historic Places, or designated as historic under an appropriate State or local law.

Place of Public Accommodation. A *facility*, operated by a private entity, whose operations affect commerce and fall within at least one of the following categories:

- Places of lodging;
- Establishments serving food and drink;
- Places of exhibition or entertainment;
- Places of public gathering;
- Sales or rental establishments;
- Service establishments;
- Stations used for specified public transportation;
- Places of public display or collection;
- Places of recreation;
- Places of education;
- Social service center establishments; or
- Places of exercise or recreation.

Public entity. Defined as:

- Any State or local government;
- Any department, agency, special purpose district, or other instrumentality of a State or States or local government; and
- The National Railroad Passenger Corporation, and any commuter authority (as defined in section 103(8) of the Rail Passenger Service Act). (45 U.S.C. 541)

Readily Achievable. Easily accomplishable and able to be carried out without much difficulty or expense. *Note: Items subject to this definition are considered on a case-by-case basis, with evaluations of all contributing factors such as cost, physical conditions and impacts on the operation of the building or *facility*.

Technically Infeasible (Technical Feasibility). With respect to an *alteration* of a *building* or a *facility*, something that has little likelihood of being accomplished because existing structural conditions would require removing or altering a load-bearing member that is an essential part of the structural frame; or because other existing physical or site constraints prohibit modification or *addition* of elements, spaces, or features that are in full and strict compliance with the minimum requirements.

201 Application

201.1 Scope. This code establishes standards for accessibility to places of *public accommodation* and commercial *facilities* by individuals with disabilities. This code shall also apply to state and local government *facilities*, private clubs and residential *buildings*. All new or altered public *buildings* and *facilities*, private *buildings* and *facilities*, places of *public accommodation* and commercial *facilities* subject to this code shall comply with this code. This code applies to all areas of newly designed and newly constructed *buildings* and *facilities*, portions of altered *buildings* and *facilities*, a *building* or *facility* that is being converted from residential to nonresidential or mixed use as defined by the Florida Building Code, *buildings* and *facilities* where the original construction or any former *alteration* or renovation was carried out in violation of applicable permitting law.

201.1.1 Vertical accessibility. Sections 553.501-553.513, F.S., and the ADA Standards for Accessible Design do not relieve the owner of any *building*, structure or *facility* governed by those sections from the duty to provide vertical accessibility to all levels above and below the occupiable grade level regardless of whether the Standards require an elevator to be installed in such *building*, structure or *facility*, except for:

- Elevator pits, elevator penthouses, mechanical rooms, piping or equipment catwalks and automobile lubrication and maintenance pits and platforms.
- Unoccupiable spaces, such as rooms, enclosed spaces and storage spaces that are not designed for human occupancy, for *public accommodations* or for work areas.
- Occupiable spaces and rooms that are not open to the public and that house no more than five persons, including, but not limited to equipment control rooms and projection booths.
- Theaters, concert halls, and stadiums, or other large assembly areas that have stadium-style seating or tiered seating if sections 221 and 802 are met.
- All play and recreation areas if the requirements of chapter 10 are met.
- All employee areas as exempted by 203.9.
- *Facilities*, sites and spaces exempted by section 203.

201.2.1 Commercial *facilities* and places of *public accommodation* located in private residences.

201.2.1.1 When a commercial *facility* or place of *public accommodation* is located in a private residence, the portion of the residence used exclusively as a residence is not covered by this subpart, but that portion used exclusively in the operation of the commercial *facility* or that portion used both for the commercial *facility* and for residential purposes is covered by the new construction and *alterations* requirements of this subpart.

202 Existing Buildings and Facilities

202.2 Additions. Each *addition* to an existing *building* or *facility* shall comply with the requirements for new construction. Each *addition* that affects or could affect the usability of or access to an area containing a *primary function* shall comply with 202.4.

202.3 Alterations. Where existing elements or spaces or common areas are altered, each altered element space or area shall comply with the applicable requirements of Chapter 2 and section 201.1.1. See Section 208.1 for existing parking. ***NOTE: This does not include normal maintenance (reroofing, painting, wallpapering, hazardous material abatement, changes to electrical and mechanical systems, etc.) or Repairs as defined in sections 202 and 404 of the 2014 Florida Building Code - Existing Building.**

EXCEPTIONS:

1. Unless required by 202.4, where elements or spaces are altered and the *circulation path* to the altered element or space is not altered, an *accessible* route shall not be required.
2. In *alterations*, where compliance with applicable requirements is *technically infeasible*, the *alteration* shall comply with the requirements to the *maximum extent feasible*.
3. Residential dwelling units not required to be *accessible* shall not be required to comply with 202.3.

Advisory 202.3 Alterations. Although covered entities are permitted to limit the scope of an alteration to individual elements, the alteration of multiple elements within a room or space may provide a cost-effective opportunity to make the entire room or space accessible. Any elements or spaces of the building or facility that are required to comply with these requirements must be made accessible within the scope of the alteration, to the maximum extent feasible. If providing accessibility in compliance with these requirements for people with one type of disability (e.g., people who use wheelchairs) is not feasible, accessibility must still be provided in compliance with the requirements for people with other types of disabilities (e.g., people who have hearing impairments or who have vision impairments) to the extent that such accessibility is feasible. Florida requirements for existing parking s.553.5041(g), F.S., and vertical accessibility s.553.509, F.S., are incorporated into this general section applicable to *alterations*. Florida requirements may be waived down to the ADA Standards requirements.

202.3.1 Prohibited Reduction in Access. An *alteration* that decreases or has the effect of decreasing the accessibility of a *building* or *facility* below the requirements for new construction at the time of the *alteration* is prohibited.

202.3.2 Extent of Application. An *alteration* of an existing element, space, or area of a *building* or *facility* shall not impose a requirement for accessibility greater than required for new construction.

202.3.3 Barriers at Common or Emergency Entrances and Exits. Barriers at common or emergency *entrances* and exits of business establishments conducting business with the general public that are existing, under construction, or under contract for construction which would prevent a person from using such *entrances* or exits shall be removed.

202.4 Alterations Affecting Primary Function Areas. In addition to the requirements of 202.3, an *alteration* that affects or could affect the usability of or access to an area containing a *primary function* shall be made so as to ensure that, to the *maximum extent feasible*, the *path of travel* to the altered area, including the rest rooms, telephones, and drinking fountains serving the altered area, are readily *accessible* to and usable by individuals with disabilities, unless such *alterations* are disproportionate to the overall *alterations* in terms of cost pursuant to 202.4.1. *Alterations* to windows, hardware, controls, electrical outlets, and signage shall not be deemed to be *alterations* that affect the usability of or access to an area containing a *primary function*.

EXCEPTIONS:

1. *Residential dwelling units shall not be required to comply with 202.4*
2. If a private entity has constructed or altered required elements of a *path of travel* at a place of *public accommodation* or commercial *facility* in accordance with the specifications in the 1994 or 1997 Florida Accessibility Code, the private entity is not required to retrofit such elements to reflect incremental changes in the proposed standards solely because of an *alteration* to a *primary function* area served by that *path of travel*.
3. The *path of travel* requirements shall not apply to measures taken solely to comply with barrier removal requirements.
4. If a *public entity* has constructed or altered required elements of a *path of travel* in accordance with the specifications in either the 1994 or 1997 Florida Accessibility Code or the Uniform Federal Accessibility Standards, as an equivalent facilitation, before March 15, 2012, the *public entity* is not required to retrofit such elements to reflect incremental changes in this code solely because of an *alteration* to a *primary function* area served by that *path of travel*.
5. The *path of travel* requirement shall not apply to *alterations* undertaken solely for purposes of meeting the *public entity* program accessibility requirements of § 35.150, 28 CFR 35.
6. If a tenant is making *alterations* that would trigger the requirements of this section, those *alterations* by the tenant in areas that only the tenant occupies do not trigger a *path of travel* obligation upon the landlord with respect to areas of the *facility* under the landlord's authority, if those areas are not otherwise being altered.

202.4.1 Disproportionate Cost. *Alterations* made to provide an *accessible path of travel* to the altered area will be deemed disproportionate to the overall *alteration* when the cost exceeds 20% of the cost of the *alteration* to the *primary function* area. Costs that may be counted as expenditures required to provide an *accessible path of travel* may include:

1. costs associated with providing an *accessible entrance* and an *accessible* route to the altered area;
2. costs associated with making restrooms *accessible*, such as installing grab bars, enlarging toilet stalls, insulating pipes, or installing *accessible* faucet controls;
3. costs associated with providing *accessible* telephones, such as relocating the telephone to an *accessible* height, installing amplification devices, or installing a text telephone (TTY); or
4. costs associated with relocating an inaccessible drinking fountain.

202.4.2 Accessible Features in the Event of Disproportionality. When the cost of *alterations* necessary to make the *path of travel* to the altered area fully *accessible* is disproportionate to the cost of the overall *alteration*, the *path of travel* shall be made *accessible* to the extent that it can be made *accessible* without incurring *disproportionate costs*. In choosing which *accessible* elements to provide, priority should be given to those elements that will provide the greatest access, in the following order:

1. an *accessible entrance*;
2. an *accessible* route to the altered area;
3. at least one *accessible* restroom for each sex or a single unisex restroom;
4. *accessible* telephones;
5. *accessible* drinking fountains; and
6. when possible, additional *accessible* elements such as parking, storage, and alarms.

202.5 Alterations to Qualified Historic Buildings and Facilities. *Alterations* to a *qualified historic building or facility* shall comply with 202.3 and 202.4 to the *maximum extent feasible*.

EXCEPTION: Where the State Historic Preservation Officer or Advisory Council on Historic Preservation determines that compliance with the requirements for *accessible* routes, *entrances*, or toilet *facilities* would threaten or destroy the historic significance of the *building or facility*, the exceptions for *alterations* to qualified historic *buildings or facilities* for that element shall be permitted to apply.

Advisory 202.5 Alterations to Qualified Historic Buildings and Facilities Exception. State Historic Preservation Officers are State appointed officials who carry out certain responsibilities under the National Historic Preservation Act. State Historic Preservation Officers consult with Federal and State agencies, local governments, and private entities on providing access and protecting significant elements of qualified historic buildings and facilities. There are exceptions for *alterations* to qualified historic buildings and facilities for accessible routes (206.2.1 Exception 1); *entrances* (206.4 Exception 2); and toilet facilities (213.2 Exception 2). When an entity believes that compliance with the requirements for any of these elements would threaten or destroy the historic significance of the building or *facility*, the entity should consult with the State Historic Preservation Officer. If the State Historic Preservation Officer agrees that compliance with the requirements for a specific element would threaten or destroy the historic significance of the building or *facility*, use of the exception is permitted. Public entities have an additional obligation to achieve program accessibility under the Department of Justice ADA regulations. See 28 CFR 35.150. These regulations require public entities that operate *historic preservation programs* to give priority to methods that provide physical access to individuals with disabilities. If *alterations to a qualified historic building or facility* to achieve program accessibility would threaten or destroy the historic significance of the building or *facility*, fundamentally alter the program, or result in undue financial or administrative burdens, the Department of Justice ADA regulations allow alternative methods to be used to achieve program accessibility. In the case of *historic preservation programs*, such as an historic house museum, alternative methods include using audio-visual materials to depict portions of the house that cannot otherwise be made accessible or adopting other innovative methods. In the case of other qualified *historic properties*, such as an historic government office building, alternative methods include relocating programs and services to accessible locations. The Department of Justice ADA regulations also allow public entities to use alternative methods when altering qualified historic buildings or facilities where the State Historic Preservation Officer determines that it is not feasible to provide physical access using the exceptions permitted in Section 202.5 without threatening or destroying the historic significance of the building or facility (see 28 CFR 35.151(d)).

202.6 Architectural Barrier Removal. Removal of architectural barriers, pursuant to 28 C.F.R. s. 36.304, from *buildings*, structures or *facilities* shall comply with this code's requirements for *alterations* unless compliance would render the removal not *readily achievable*. In no instance shall the removal of an architectural barrier create a significant risk to the health or safety of an individual with a disability or others.

202.6.1 Measures taken to comply with federal barrier removal requirements shall comply with the applicable requirements for *Alterations* for the element being altered.

EXCEPTIONS:

1. The *path of travel* requirements of 202.4 shall not apply to measures taken solely to comply with federal architectural barrier removal requirements.
2. If the measures required to remove a barrier would not be *readily achievable*, a *public accommodation* may take other *readily achievable* measures to remove the barrier that do not fully comply with the specified requirements. Such measures include but are not limited to providing a ramp with a steeper slope or widening a doorway to a narrower width than that mandated by the *alterations* requirements.

203 General Exceptions

203.1 General. Sites, *buildings, facilities*, and elements are exempt from these requirements to the extent specified by 203.

203.2 – 203.15 Specific Exemptions (see full text of FACBC for conditions)

- Construction Sites
- Raised Areas
- Limited Access Spaces
- Machinery Spaces
- Single Occupant Structure
- Detention and Correctional Facilities
- Raised Refereeing, Judging, and Scoring
- Employee Work Areas
- Structural impracticability
- Water Slides
- Animal Containment Areas
- Raised Boxing or Wrestling Rings
- Residential Facilities
- Raised Diving Boards and Diving Platforms

206 Accessible Routes

206.2.1 Site Arrival Points. At least one *accessible* route shall be provided within the site from *accessible* parking spaces and *accessible* passenger loading zones, public streets and sidewalks, and public transportation stops to the *accessible building or facility entrance* they serve.

EXCEPTIONS:

1. Where exceptions for *alterations* to qualified historic *buildings or facilities* are permitted by 202.5, no more than one *accessible* route from a site arrival point to an *accessible entrance* shall be required.
2. An *accessible* route shall not be required between site arrival points and the *building or facility entrance* if the only means of access between them is a vehicular way not providing pedestrian access.

206.2.4 Spaces and Elements. At least one *accessible* route shall connect *accessible building or facility entrances* with all *accessible* spaces and elements within the *building or facility* which are otherwise connected by a *circulation path*.

206.4 Entrances. *Entrances* shall be provided in accordance with 206.4. *Entrance* doors, doorways, and gates shall comply with 404 and shall be on an *accessible* route complying with 402.

EXCEPTIONS:

1. Where an *alteration* includes *alterations* to an *entrance*, and the *building or facility* has another *entrance* complying with 404 that is on an *accessible* route, the altered *entrance* shall not be required to comply with 206.4 unless required by 202.4.
2. Where exceptions for *alterations* to qualified historic *buildings or facilities* are permitted by 202.5, no more than one *public entrance* shall be required to comply with 206.4. Where no *public entrance* can comply with 206.4 under criteria established in 202.5 Exception, then either an unlocked *entrance* not used by the public shall comply with 206.4; or a locked *entrance* complying with 206.4 with a notification system or remote monitoring shall be provided.

213 Toilet Facilities and Bathing Facilities

213.1 General. Where toilet *facilities* and bathing *facilities* are provided, they shall comply with 213. Where toilet *facilities* and bathing *facilities* are provided in *facilities* permitted by 206.2.3 Exceptions 1 and 2 not to connect stories by an *accessible* route, toilet *facilities* and bathing *facilities* shall be provided on a story connected by an *accessible* route to an *accessible entrance*.

213.2 Toilet Rooms and Bathing Rooms. Where toilet rooms are provided, each toilet room shall comply with 603. Where bathing rooms are provided, each bathing room shall comply with 603.

EXCEPTIONS:

1. In *alterations* where it is *technically infeasible* to comply with 603, altering existing toilet or bathing rooms shall not be required where a single unisex toilet room or bathing room complying with 213.2.1 is provided and located in the same area and on the same floor as existing inaccessible toilet or bathing rooms.
2. Where exceptions for *alterations* to qualified historic buildings or *facilities* are permitted by 202.5, no fewer than one toilet room for each sex complying with 603 or one unisex toilet room complying with 213.2.1 shall be provided.
3. Where multiple single user portable toilet or bathing units are clustered at a single location, no more than 5 percent of the toilet units and bathing units at each cluster shall be required to comply with 603. Portable toilet units and bathing units complying with 603 shall be identified by the International Symbol of Accessibility complying with 703.7.2.1.
4. Where multiple single user toilet rooms are clustered at a single location, no more than 50 percent of the single user toilet rooms for each use at each cluster shall be required to comply with 603.

How to Use the ADA Checklist

Get Organized. One person can conduct a survey, but it's easier with two people. One person can take measurements and the other person can fill out the checklist and take photos.

Obtain Floor Plans. A floor plan or sketch helps the surveyors get oriented and know how many elements, such as drinking fountains and *entrances*, there are and where they are. If plans are not available, sketch the layout of interior and exterior spaces.

Gather Tools

- Checklist
- Clipboard makes it easier to write on the checklist
- Tape measure
- Electronic or carpenter's level - 24 inches
- Door pressure gauge or fish scale for measuring door-opening force
- Digital camera

Conduct the Survey

Start Outside. Start from site arrival points such as drop-off areas and public sidewalks and determine if there is an accessible route to an accessible *entrance*. If there is a parking lot or garage check for the correct number of accessible parking spaces, including van-accessible spaces. Is there an accessible route from the accessible parking spaces to an accessible *entrance*? Next survey the *entrances*. If there is an accessible *entrance*, determine if there are signs at inaccessible *entrances* directing people to the accessible *entrance*. Go inside and continue through the *facility* and the checklist.

Take Good Measurements. When in doubt write it down. It's better to have too much information than not enough. Even if something is in compliance it's helpful to have exact measurements.



Parking Spaces

Measure from the inside edge of the painted line to the inside of the opposite painted line or edge of space.



Door Clear Width

Open the door 90 degrees, measure from the face of the door to the edge of the door stop.

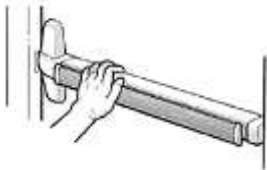

Door Opening Force

If you're using a door pressure gauge place it where you would push open the door. If you're using a force scale place it where you would pull open the door.

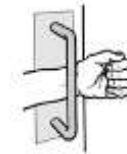

Accessible Slopes

You can measure slope with a 24 inch level and a tape measure. Put the level on the surface in the direction you are measuring. Put one end at the high point of the surface and raise the other end so that the bubble is in the middle of the level's gauge. The level is now level. Measure the distance between the end of the level at its bottom point and the surface. For a ramp the maximum running slope allowed is 1:12. That means for every inch of height change there should be at least 12 inches of ramp run.

For the parts of an accessible route that aren't a ramp, the maximum running slope allowed is 1:20. That means for every inch of height change there must be at least 20 inches of route run.

For the cross slope of an accessible route the maximum slope allowed is 1:48. The distance from the bottom edge of the level to the surface should be no more than ½ inch. The cross slope of an accessible route is the slope that is perpendicular to the direction of pedestrian travel.

Check that you have everything. Before you leave the site review all the checklists. Make sure you know which checklist goes with which *entrance* and which toilet room and that you've got all the information you need. It is better to do it now than to have to go back.

After the Survey

List Barriers and Solutions. Consider the solutions listed beside each question on the checklist and add your own ideas. Consult with building contractors and equipment suppliers to estimate the costs for making modifications.

Develop an Implementation Plan. Although an implementation plan is not required, the Department of Justice recommends such a plan, specifying what barriers will be removed and when solutions will occur: "...Such a plan...could serve as evidence of a good faith effort to comply..." Prioritize items, make a timeline and develop a budget. Where the removal of barriers is not *readily achievable*, consider whether there are alternative methods for providing access that are *readily achievable* such as curbside takeout service at a restaurant with an accessible intercom system outside.

Make Changes. Check whether local and state building codes require greater accessibility when *alterations* are undertaken.

Additional Resources and References

- Fifth Edition (2014) Florida Building Codes
- Fifth Edition (2014) Florida Accessibility Code for Building Construction
- 2010 ADA Standards for Accessible Design
- Florida Statutes Sections 553.501 - 553.514
- The Secretary of the Interior's Standards for Rehabilitation and Guidelines for Rehabilitating Historic Buildings

Public Entities (State and Local Governments)

Code of Federal Regulations Title 28 CFR Part 35

- 28 CFR 35.150 (existing buildings)
- 28 CFR 35.151 (new construction/*alterations*)
- 28 CFR 35.150 Alternatives

Private Entities (Public Accommodations / Commercial Facilities)

Code of Federal Regulations Title 28 CFR Part 36

28 CFR 36.304 Removal of Barriers

Contacts for Additional Information

Florida Dept. of State Division of Historical Resources, Bureau of Historic Preservation

850.245.6333

dos.myflorida.com/historical/preservation/architectural-services

US Dept. of the Interior National Park Service, Technical Preservation Services

202.513.7270

nps.gov/tps/

Florida Dept. of Business and Professional Regulation, Florida Building Commission

850.487.1824

floridabuilding.org

U.S. Department of Justice ADA Information

800.514.0301

ada.gov

Institute for Human Centered Design

617.695.1225

humancentereddesign.org

ADA National Network

800.949.4232

adata.org/

ADA Checklist for Readily Achievable Barrier Removal

Priority 1 – Approach & Entrance



NOTE: Alterations to Qualified Historic Buildings and Facilities shall comply with the Florida Accessibility Code for Building Construction (FACBC) to the *maximum extent feasible*. All proposed changes to achieve compliance with the FACBC should be reviewed by the State Historic Preservation Officer (SHPO) prior to undertaking any required or suggested corrective measures described herein to avoid diminishing or destroying the historic significance of the Buildings or Facilities. There are exceptions to compliance with the FACBC for Qualified Historic Buildings and Facilities. Consult the SHPO for more information where indicated.

Project: _____

Building: _____

Location: _____

Date: _____

Surveyors: _____

SHPO Contact Information :



Florida Department of State
Division of Historical Resources, Bureau of Historic Preservation
500 South Bronough St.
Tallahassee, Florida 32399

dos.myflorida.com/historical/preservation/architectural-services

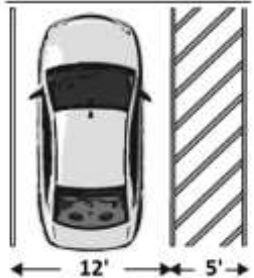
850.245.6333

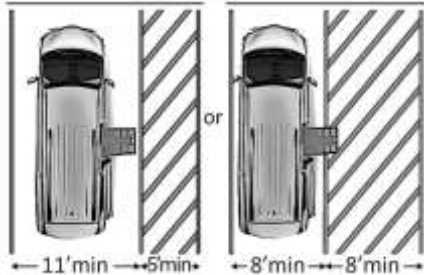
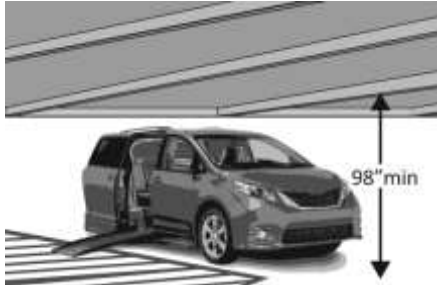
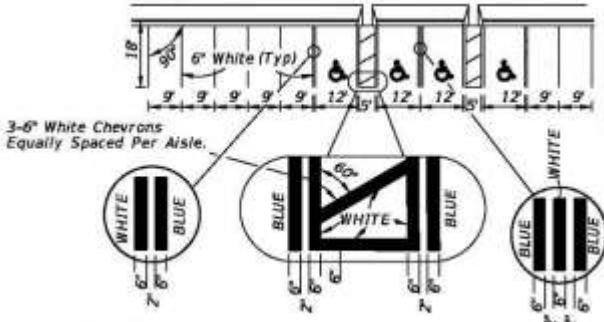
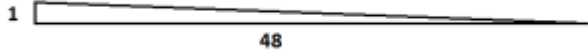
Priority 1 – Approach & Entrance		Code Requirements	2014 Florida Accessibility Code Section No.	Possible Solutions												
<p>1.1 Is there at least one route from site arrival points (parking, passenger loading zones, public sidewalks and public transportation stops) that does not require the use of stairs?</p>	<input type="checkbox"/> Yes <input type="checkbox"/> No If yes, location of route:		202.5, 206.2 **Consult SHPO** Photo #:	<ul style="list-style-type: none"> SHPO to evaluate and if no adverse impact to historic significance, add a ramp, regrade to 1:20 maximum slope or add a lift if site constraints prevent other solutions 												
Parking Note: Accessible parking spaces should be identified by size, access aisle and signage.																
<p>1.2 If parking is provided for the public, are an adequate number of accessible spaces provided?</p>	<input type="checkbox"/> Yes <input type="checkbox"/> No Total #: Accessible #:	<table border="1" style="width: 100%; text-align: center;"> <thead> <tr> <th>Total Spaces</th> <th>Accessible Spaces</th> </tr> </thead> <tbody> <tr> <td>1 - 25</td> <td>1</td> </tr> <tr> <td>26 - 50</td> <td>2</td> </tr> <tr> <td>51 - 75</td> <td>3</td> </tr> <tr> <td>76 - 100</td> <td>4</td> </tr> <tr> <td colspan="2">100+ see FACBC 208.2</td> </tr> </tbody> </table>	Total Spaces	Accessible Spaces	1 - 25	1	26 - 50	2	51 - 75	3	76 - 100	4	100+ see FACBC 208.2		208.2 Photo #:	<ul style="list-style-type: none"> Reconfigure by repainting lines
Total Spaces	Accessible Spaces															
1 - 25	1															
26 - 50	2															
51 - 75	3															
76 - 100	4															
100+ see FACBC 208.2																
<p>1.3 Of the accessible spaces, is at least one a van accessible space?*</p>	<input type="checkbox"/> Yes <input type="checkbox"/> No	*For every 6 or fraction of 6 parking spaces required by the table above, at least 1 should be a van accessible space.	208.2.4 Photo #:	<ul style="list-style-type: none"> Reconfigure by repainting lines 												
<p>1.4 Are accessible spaces at least 12 feet wide with an access aisle at least 5 feet wide? Two spaces can share an access aisle. *Note: On street parallel parking is allowed to be 8 feet wide</p>	<input type="checkbox"/> Yes <input type="checkbox"/> No Measurement:	 <p style="text-align: center;"> 12' 5' </p>	502.2, 502.3 Photo #:	<ul style="list-style-type: none"> Reconfigure by repainting lines 												

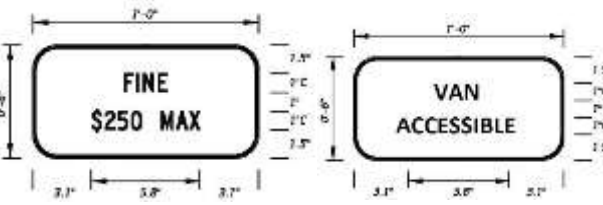

<p>1.5 Is the van accessible space:</p> <p>At least 11 feet wide with an access aisle at least 5 feet wide? Or At least 8 feet wide with an access aisle at least 8 feet wide?</p>	<p><input type="checkbox"/> Yes <input type="checkbox"/> No</p> <p>Measurement:</p>		<p>502.2</p> <p>Photo #:</p>	<ul style="list-style-type: none"> Reconfigure to provide van-accessible space(s)
<p>1.6 Is at least 98 inches of vertical clearance provided for the van accessible space?</p>	<p><input type="checkbox"/> Yes <input type="checkbox"/> No</p> <p>Measurement:</p>		<p>502.5</p> <p>Photo #:</p>	<ul style="list-style-type: none"> Reconfigure to provide van-accessible space(s)
<p>1.7 Are the access aisles marked so as to discourage parking in them?</p>	<p><input type="checkbox"/> Yes <input type="checkbox"/> No</p>		<p>502.3.3</p> <p>Photo #:</p>	<ul style="list-style-type: none"> Mark access aisles with white diagonal striping per FDOT Standards
<p>1.8 Is the slope of the accessible parking spaces and access aisles no steeper than 1:48 in all directions?</p>	<p><input type="checkbox"/> Yes <input type="checkbox"/> No</p> <p>Measurement</p>		<p>502.4</p> <p>Photo #:</p>	<ul style="list-style-type: none"> Regrade surface

<p>1.9 Do the access aisles adjoin an accessible route?</p> <p><input type="checkbox"/> Yes <input type="checkbox"/> No</p>	<p><input type="checkbox"/> Yes <input type="checkbox"/> No</p>		<p>502.3</p> <p>Photo #:</p>	<ul style="list-style-type: none"> • Create accessible route • Relocate accessible space
<p>1.10 Are accessible spaces Identified with a sign that complies with an FDOT approved design?</p> <p>In Parking Structures, are Van Accessible spaces Identified with a sign that complies with an FDOT approved design?</p> <p>Is the bottom of the sign at least 60 inches above the ground?</p>	<p><input type="checkbox"/> Yes <input type="checkbox"/> No</p> <p><input type="checkbox"/> Yes <input type="checkbox"/> No</p> <p>Measurement:</p> <p><input type="checkbox"/> Yes <input type="checkbox"/> No</p>		<p>502.6</p> <p>Photo #:</p>	<ul style="list-style-type: none"> • Install FDOT Standard signs with bottom 60 inches above the ground <p>NOTE: The International Symbol of Accessibility is not required to be painted on the pavement.</p>
<p>1.11 Are "Indication of Penalty" supplemental signs provided at each accessible parking space?</p> <p>Are "VAN ACCESSIBLE" supplemental signs provided at van accessible parking spaces?</p>	<p><input type="checkbox"/> Yes <input type="checkbox"/> No</p> <p><input type="checkbox"/> Yes <input type="checkbox"/> No</p>		<p>502.6</p> <p>Photo #:</p>	<ul style="list-style-type: none"> • Install FDOT Standard Supplemental signs below Parking signs
<p>1.12 Of the total parking spaces, are the accessible spaces located on the closest accessible route to the accessible entrance(s)?</p>	<p><input type="checkbox"/> Yes <input type="checkbox"/> No</p>		<p>208.3.1</p> <p>Photo #:</p>	<ul style="list-style-type: none"> • Reconfigure spaces If parking lot serves multiple entrances, accessible parking should be dispersed

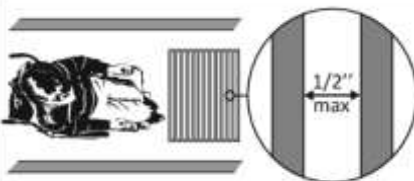
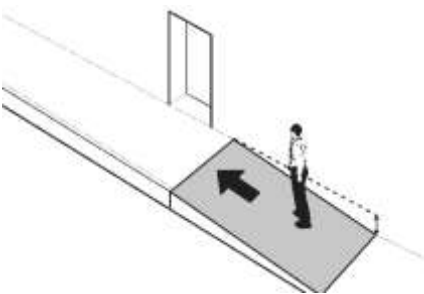
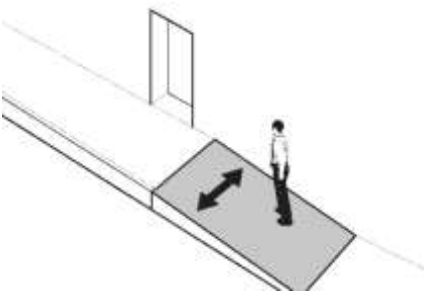
Exterior Accessible Route				
<p>1.13 Is the route stable, firm and slip-resistant?</p>	<p><input type="checkbox"/> Yes <input type="checkbox"/> No</p>		<p>302.1</p> <p>Photo #:</p>	<ul style="list-style-type: none"> • Repair uneven paving • Fill small bumps and breaks with patches • Replace gravel with stable surface
<p>1.14 Is the route at least 36 inches wide?</p> <p>Note: The accessible route can narrow to 32 inches min. for a max. of 24 inches. These narrower portions of the route must be at least 48 inches from each other.</p>	<p><input type="checkbox"/> Yes <input type="checkbox"/> No</p> <p>Measurement:</p>		<p>202.5, 403.5.1</p> <p>**Consult SHPO**</p> <p>Photo #:</p>	<ul style="list-style-type: none"> • SHPO to evaluate and if no adverse impact to historic significance, change or move landscaping, furnishings or other items to the <i>maximum extent feasible</i> in order to widen route
<p>1.15 If the route is greater than 200 feet in length and no less than 60 inches wide, is there a passing space no less than 60 x 60 inches?</p>	<p><input type="checkbox"/> Yes <input type="checkbox"/> No</p> <p>Measurement:</p>		<p>202.5, 403.5.3</p> <p>**Consult SHPO**</p> <p>Photo #:</p>	<ul style="list-style-type: none"> • SHPO to evaluate and if no adverse impact to historic significance, <i>disproportionate costs</i> or technical infeasibility, widen route for passing space to the <i>maximum extent feasible</i>

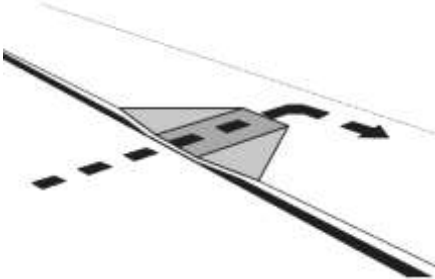
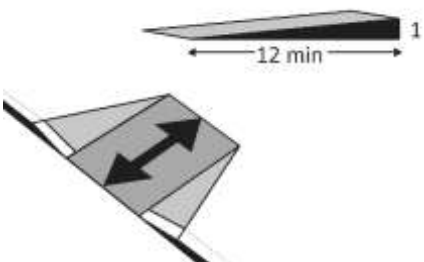
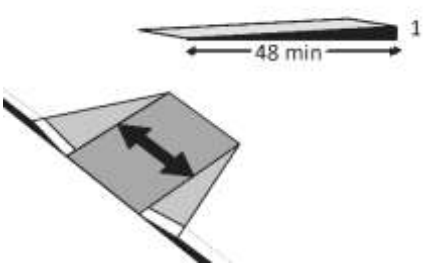
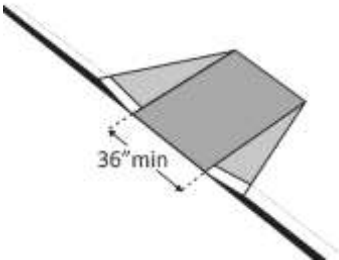
<p>1.16 If there are grates or openings on the route, are the openings no larger than ½ inches to the dominant direction of travel?</p> <p>Is the long dimension perpendicular to the dominant direction of travel?</p>	<p><input type="checkbox"/> Yes <input type="checkbox"/> No</p> <p>Measurement:</p> <p><input type="checkbox"/> Yes <input type="checkbox"/> No</p>		<p>302.3</p> <p>Photo #:</p>	<ul style="list-style-type: none"> • Replace or move grate
<p>1.17 Is the running slope no steeper than 1:20, i.e. for every inch of height change there are at least 20 inches of route run?</p>	<p><input type="checkbox"/> Yes <input type="checkbox"/> No</p> <p>Measurement:</p>		<p>202.5, 403.3</p> <p>**Consult SHPO**</p> <p>Photo #:</p>	<ul style="list-style-type: none"> • SHPO to evaluate and if no adverse impact to historic significance, re-grade to 1:20 max. • If steeper than 1:20 and no steeper than 1:12, treat as a ramp and add other features such as edge protection and handrails
<p>1.18 Is the cross slope no steeper than 1:48?</p>	<p><input type="checkbox"/> Yes <input type="checkbox"/> No</p> <p>Measurement:</p>		<p>202.5, 403.3</p> <p>**Consult SHPO**</p> <p>Photo #:</p>	<ul style="list-style-type: none"> • SHPO to evaluate and if no adverse impact to historic significance, re-grade to 1:48 max.

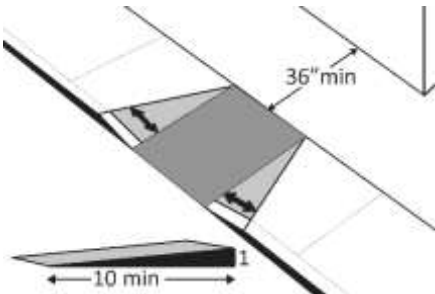
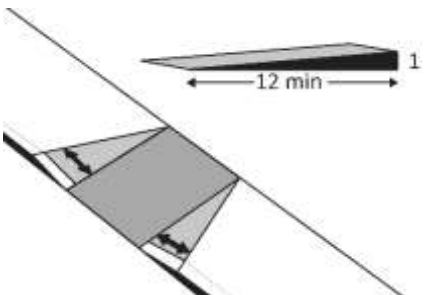
Curb Ramps				
<p>1.19 If the accessible route crosses a curb, is there a curb ramp?</p>	<p><input type="checkbox"/> Yes <input type="checkbox"/> No</p>		<p>406</p> <p>Photo #:</p>	<ul style="list-style-type: none"> • Install curb ramp
<p>1.20 Is the running slope of the curb ramp no steeper than 1:12, i.e. for every inch of height change there are at least 12 inches of curb ramp run?</p>	<p><input type="checkbox"/> Yes <input type="checkbox"/> No</p> <p>Measurement:</p>		<p>405.2, 406.1</p> <p>Photo #:</p>	<ul style="list-style-type: none"> • Re-grade curb ramp
<p>1.21 Is the cross slope of the curb ramp, excluding flares, no steeper than 1:48?</p>	<p><input type="checkbox"/> Yes <input type="checkbox"/> No</p> <p>Measurement:</p>		<p>405.3, 406.1</p> <p>Photo #:</p>	<ul style="list-style-type: none"> • Re-grade curb ramp
<p>1.22 Is the curb ramp, excluding flares, at least 36 inches wide?</p>	<p><input type="checkbox"/> Yes <input type="checkbox"/> No</p> <p>Measurement:</p>		<p>405.5, 406.1</p> <p>Photo #:</p>	<ul style="list-style-type: none"> • Widen curb ramp

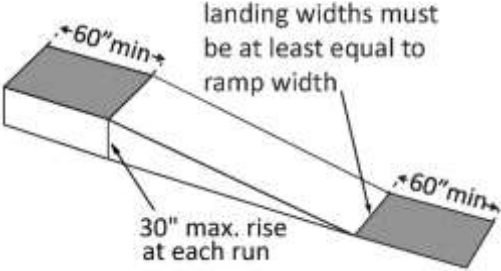

<p>1.23 At the top of the curb ramp is there a level landing (slope no steeper than 1:48 in all directions) that is at least 36 inches long and at least as wide as the curb ramp?</p> <p>If there are curb ramp flares, are the slopes of the flares no steeper than 1:10?</p>	<p><input type="checkbox"/> Yes <input type="checkbox"/> No Measurement:</p> <p><input type="checkbox"/> Yes <input type="checkbox"/> No Measurement:</p>		<p>406.4</p> <p>Photo #:</p>	<ul style="list-style-type: none"> • Reconfigure • Add ramp flares
<p>1.24 If the landing at the top is less than 36 inches long, are there curb ramp flares?</p> <p>Are the slopes of the flares no greater than 1:12, i.e. for every inch of height change there are at least 12 inches of flare run?</p>	<p><input type="checkbox"/> Yes <input type="checkbox"/> No Measurement:</p> <p><input type="checkbox"/> Yes <input type="checkbox"/> No Measurement:</p>		<p>406.4</p> <p>Photo #:</p>	<ul style="list-style-type: none"> • Add ramp flares • Re-grade flares
<p>Ramps (2010 Standards – 405 & 505) Note: If any portion of the accessible route is steeper than 1:20, it should be treated as a ramp.</p>				
<p>1.25 If there is a ramp (other than curb ramps), is it at least 36 inches wide? If there are handrails, measure between the handrails.</p>	<p><input type="checkbox"/> Yes <input type="checkbox"/> No Measurement:</p>		<p>202.5, 405.5</p> <p>**Consult SHPO**</p> <p>Photo #:</p>	<ul style="list-style-type: none"> • SHPO to evaluate and if no adverse impact to historic significance, alter ramp

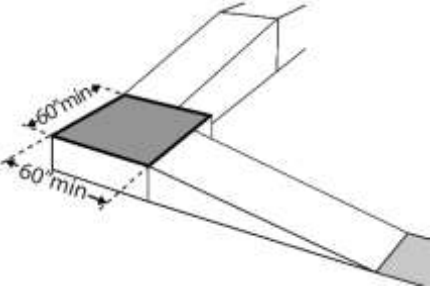
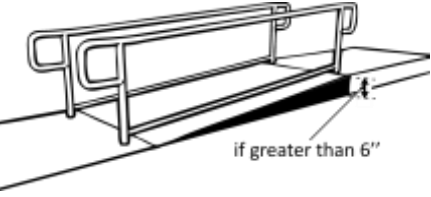
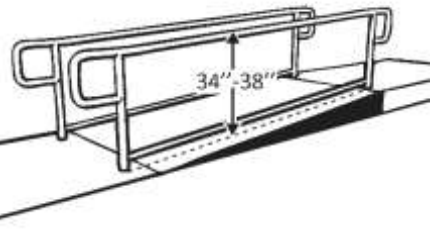
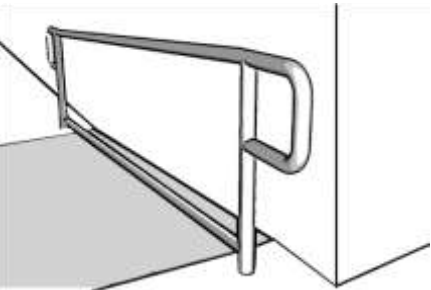

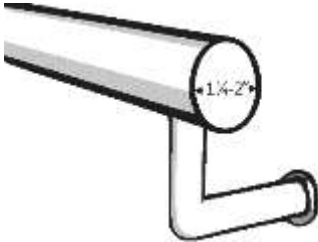
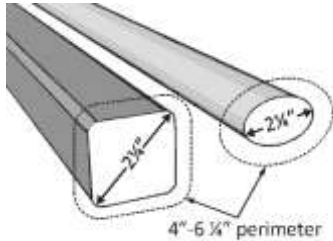
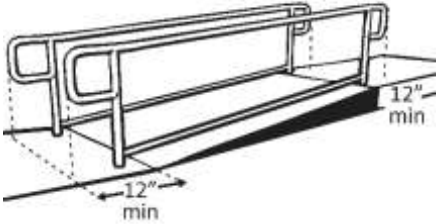
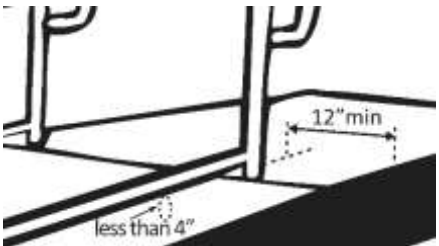
<p>1.26 Is the surface stable, firm and slip resistant?</p>	<p><input type="checkbox"/> Yes <input type="checkbox"/> No</p>		<p>405.4</p> <p>Photo #:</p>	<ul style="list-style-type: none"> • Resurface ramp
<p>1.27 For each section of the ramp, is the running slope no greater than 1:12, i.e. for every inch of height change there are at least 12 inches of ramp run?</p> <p>Note: Existing Buildings and Facilities - Rises no greater than 3 inches with a slope no steeper than 1:8 and rises no greater than 6 inches with a slope no steeper than 1:10 are permitted when such slopes are necessary due to space limitations.</p>	<p><input type="checkbox"/> Yes <input type="checkbox"/> No</p> <p>Measurement:</p>		<p>202.5, 405.2, 405.2 Exception</p> <p>**Consult SHPO**</p> <p>Photo #:</p>	<ul style="list-style-type: none"> • SHPO to evaluate and if no adverse impact to historic significance, alter or relocate ramp or lengthen ramp to decrease slope
<p>1.28 Is there a level landing that is at least 60 inches long and at least as wide as the ramp?</p> <p>At the top and bottom of the ramp?</p> <p>Is the maximum rise of a single run no more than 30 inches?</p>	<p><input type="checkbox"/> Yes <input type="checkbox"/> No</p> <p>Measurement:</p> <p><input type="checkbox"/> Yes <input type="checkbox"/> No</p> <p>Measurement:</p> <p><input type="checkbox"/> Yes <input type="checkbox"/> No</p> <p>Measurement:</p>		<p>202.5, 405.6, 405.7.2, 405.7.3</p> <p>**Consult SHPO**</p> <p>Photo #:</p>	<ul style="list-style-type: none"> • SHPO to evaluate and if no adverse impact to historic significance, alter ramp

<p>1.29 Is there a level landing where the ramp changes direction that is at least 60 x 60 inches?</p>	<p><input type="checkbox"/> Yes <input type="checkbox"/> No Measurement:</p>		<p>202.5, 405.7.4 **Consult SHPO** Photo #:</p>	<ul style="list-style-type: none"> • SHPO to evaluate and if no adverse impact to historic significance, alter ramp
<p>1.30 If the ramp has a rise higher than 6 inches, are there handrails on both sides? Curb ramps are not required to have handrails</p>	<p><input type="checkbox"/> Yes <input type="checkbox"/> No Measurement:</p>		<p>202.5, 405.8 **Consult SHPO** Photo #:</p>	<ul style="list-style-type: none"> • SHPO to evaluate and if no adverse impact to historic significance, add handrails
<p>1.31 Is the top of the handrail gripping surface no less than 34 inches and no greater than 38 inches above the ramp surface?</p>	<p><input type="checkbox"/> Yes <input type="checkbox"/> No Measurement:</p>		<p>202.5, 505.4 **Consult SHPO** Photo #:</p>	<ul style="list-style-type: none"> • SHPO to evaluate and if no adverse impact to historic significance, reconfigure or replace handrails
<p>1.32 Is the handrail gripping surface continuous and not obstructed along the top or sides? Is the bottom of the handrail gripping surface obstructed for no more than 20 percent of its length?</p>	<p><input type="checkbox"/> Yes <input type="checkbox"/> No <input type="checkbox"/> Yes <input type="checkbox"/> No Measurement:</p>		<p>202.5, 505.6 **Consult SHPO** Photo #:</p>	<ul style="list-style-type: none"> • SHPO to evaluate and if no adverse impact to historic significance, reconfigure or replace handrails

<p>1.33 If the handrail gripping surface is circular, is it no less than 1 ¼ inches and no greater than 2 inches in diameter?</p>	<p><input type="checkbox"/> Yes <input type="checkbox"/> No</p> <p>Measurement:</p>		<p>202.5, 505.7.1</p> <p>**Consult SHPO**</p> <p>Photo #:</p>	<ul style="list-style-type: none"> • SHPO to evaluate and if no adverse impact to historic significance, replace handrails
<p>1.34 If the handrail gripping surface is non-circular, is it no less than 4 inches and no greater than 6 ¼ inches in perimeter and no more than 2 ¼ inches in cross section?</p>	<p><input type="checkbox"/> Yes <input type="checkbox"/> No</p> <p>Measurement:</p>		<p>202.5, 505.7.2</p> <p>**Consult SHPO**</p> <p>Photo #:</p>	<ul style="list-style-type: none"> • SHPO to evaluate and if no adverse impact to historic significance, replace handrails
<p>1.35 Does the handrail:</p> <p>Extend at least 12 inches horizontally beyond the top and bottom of the ramp?</p> <p>Return to a wall, guard, or landing surface?</p>	<p><input type="checkbox"/> Yes <input type="checkbox"/> No</p> <p>Measurement:</p> <p><input type="checkbox"/> Yes <input type="checkbox"/> No</p>		<p>202.5, 505.10.1</p> <p>**Consult SHPO**</p> <p>Photo #:</p>	<ul style="list-style-type: none"> • SHPO to evaluate and if no adverse impact to historic significance, add extensions or reconfigure handrails <p>If a 12" extension would be hazardous (in circulation path), it is not required</p>
<p>1.36 To prevent wheelchair casters and crutch tips from falling off:</p> <p>Does the surface of the ramp extend at least 12 inches beyond the inside face of the handrail? Or is there a curb or barrier that prevents the passage of a 4-inch diameter sphere?</p>	<p><input type="checkbox"/> Yes <input type="checkbox"/> No</p> <p><input type="checkbox"/> Yes <input type="checkbox"/> No</p>		<p>405.9.1, 405.9.2</p> <p>Photo #:</p>	<ul style="list-style-type: none"> • Add curb • Add barrier • Extend ramp width

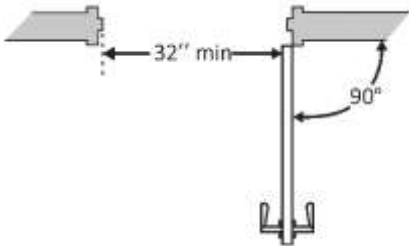
Entrance			
<p>1.37 Is the existing main <i>entrance</i> accessible?</p> <p style="text-align: right;"><input type="checkbox"/> Yes <input type="checkbox"/> No</p> <p>Will modifying the existing <i>entrance</i> have an adverse impact on the historic significance of the building?</p> <p style="text-align: right;"><input type="checkbox"/> Yes <input type="checkbox"/> No</p>			<p>202.5, 206.4 (Exception 2)</p> <p>**Consult SHPO**</p> <p>Photo #:</p>
<p>1.38 If the main <i>entrance</i> is not accessible, is there an alternative accessible <i>entrance</i>?</p> <p style="text-align: right;"><input type="checkbox"/> Yes <input type="checkbox"/> No</p> <p>Can the alternative accessible <i>entrance</i> be used independently and during the same hours as the main <i>entrance</i>?</p> <p style="text-align: right;"><input type="checkbox"/> Yes <input type="checkbox"/> No</p> <p>Note: If an alternative <i>entrance</i> not used by the public is utilized as an accessible <i>entrance</i>, it must either remain unlocked or be provided with a notification system or remote monitoring.</p>			<p>202.5, 206.4 Exception 2</p> <p>**Consult SHPO**</p> <p>Photo #:</p>

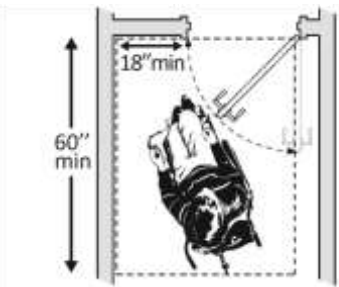
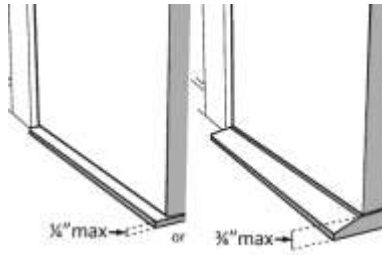
<p>1.39 Do all inaccessible <i>entrances</i> have signs indicating the location of the nearest accessible <i>entrance</i>?</p> <p>Does the sign comply with FACBC Section 703?</p>	<p><input type="checkbox"/> Yes <input type="checkbox"/> No</p> <p><input type="checkbox"/> Yes <input type="checkbox"/> No</p>		<p>216.6, 703</p> <p>Photo #:</p>	<ul style="list-style-type: none"> • Install signs in compliance with FACBC Section 703 • Install signs on route before people get to inaccessible <i>entrances</i> so that people do not have to turn around and retrace route
<p>1.40 If not all <i>entrances</i> are accessible, is there a sign at the accessible <i>entrance</i> with the International Symbol of Accessibility?</p> <p>Does the sign comply with FACBC Section 703?</p>	<p><input type="checkbox"/> Yes <input type="checkbox"/> No</p> <p><input type="checkbox"/> Yes <input type="checkbox"/> No</p>		<p>216.6, 703.7.2.1</p> <p>Photo #:</p>	<ul style="list-style-type: none"> • Install sign in compliance with FACBC Section 703
<p>1.41 Is the clear opening width of the accessible <i>entrance</i> door at least 32 inches, between the face of the door and the stop, when the door is open 90 degrees?</p>	<p><input type="checkbox"/> Yes <input type="checkbox"/> No</p> <p>Measurement:</p>		<p>202.5, 404.2.3</p> <p>**Consult SHPO**</p> <p>Photo #:</p>	<ul style="list-style-type: none"> • SHPO to evaluate and if no adverse impact to historic significance, <i>disproportionate costs</i> or technical infeasibility, alter door to make it accessible • Install offset hinges
<p>1.42 Can the exterior <i>entrance</i> door be opened easily (8.5 pounds maximum force)?</p>	<p><input type="checkbox"/> Yes <input type="checkbox"/> No</p> <p>Measurement:</p>		<p>404.2.9</p> <p>Photo #:</p>	<ul style="list-style-type: none"> • Adjust or replace closers • Install lighter doors • Install power-assisted or automatic door openers

<p>1.43 If there is a front approach to the pull side of the door, is there at least 18 inches of maneuvering clearance beyond the latch side plus at least 60 inches clear depth?</p> <p>On both sides of the door, is the ground or floor surface of the maneuvering clearance level (no steeper than 1:48)?</p>	<p><input type="checkbox"/> Yes <input type="checkbox"/> No Measurement:</p> <p><input type="checkbox"/> Yes <input type="checkbox"/> No Measurement:</p>		<p>202.5, 404.2.4.1, 404.2.4.4</p> <p>**Consult SHPO**</p> <p>Photo #:</p>	<ul style="list-style-type: none"> • SHPO to evaluate and if no adverse impact to historic significance, <i>disproportionate costs</i> or technical infeasibility, remove obstructions, reconfigure walls to the <i>maximum extent feasible</i>, reverse door swing if possible or add an automatic door opener <p>See FACBC Section 404.2.4 for maneuvering clearance requirements</p>
<p>1.44 Is the door threshold edge no more than ¼ inch high? OR No more than ¾ inch high if slope is beveled no steeper than 1:2?</p> <p>Note: The first ¼ inch of the threshold may be vertical; the rest must be beveled.</p>	<p><input type="checkbox"/> Yes <input type="checkbox"/> No Measurement:</p> <p><input type="checkbox"/> Yes <input type="checkbox"/> No Measurement:</p>		<p>303.2, 303.3, 404.2.5</p> <p>Photo #:</p>	<ul style="list-style-type: none"> • Remove or replace threshold
<p>1.45 Is the door equipped with hardware, including locks, that is operable with one hand and does not require tight grasping, pinching, or twisting of the wrist?</p>	<p><input type="checkbox"/> Yes <input type="checkbox"/> No</p>		<p>202.5, 309.4</p> <p>**Consult SHPO**</p> <p>Photo #:</p>	<ul style="list-style-type: none"> • SHPO to evaluate and if no adverse impact to historic significance, replace inaccessible knob with lever, loop or push hardware, or add an automatic door opener

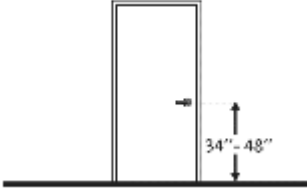
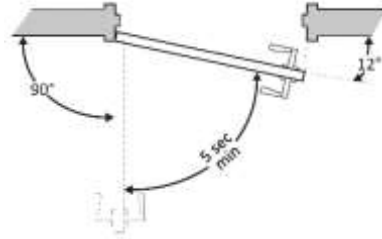
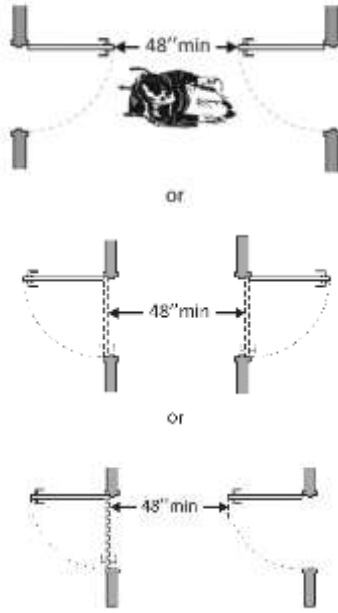
<p>1.46 Are the operable parts of the door hardware no less than 34 inches and no greater than 48 inches above the floor or ground surface?</p>	<p><input type="checkbox"/> Yes <input type="checkbox"/> No</p> <p>Measurement:</p>		<p>404.2.7</p> <p>Photo #:</p>	<ul style="list-style-type: none"> • Change hardware height
<p>1.47 If the door has a closer, does it take at least 5 seconds to close from an open position of 90 degrees to a position of 12 degrees from the latch?</p>	<p><input type="checkbox"/> Yes <input type="checkbox"/> No</p> <p>Measurement:</p>		<p>404.2.8.1</p> <p>Photo #:</p>	<ul style="list-style-type: none"> • Adjust closer
<p>1.48 If there are two doors in a series, e.g. vestibule, is the distance between the doors at least 48 inches plus the width of the doors when swinging into the space?</p>	<p><input type="checkbox"/> Yes <input type="checkbox"/> No</p> <p>Measurement:</p>		<p>404.2.6</p> <p>Photo #:</p>	<ul style="list-style-type: none"> • Remove inner door • Change door swing

ADA Checklist for Readily Achievable Barrier Removal

Priority 2 – Access to Goods & Services

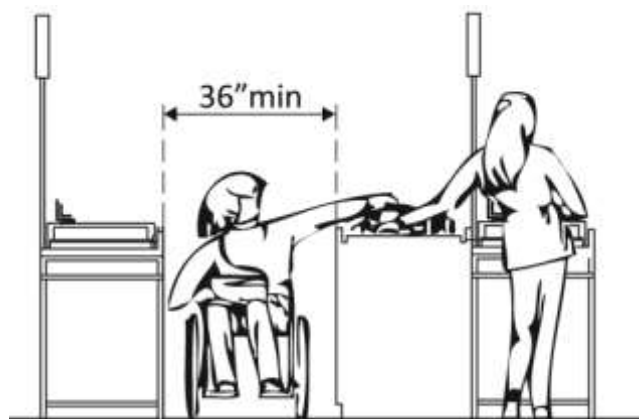

NOTE: Alterations to Qualified Historic Buildings and Facilities shall comply with the Florida Accessibility Code for Building Construction (FACBC) to the *maximum extent feasible*. All proposed changes to achieve compliance with the FACBC should be reviewed by the State Historic Preservation Officer (SHPO) prior to undertaking any required or suggested corrective measures described herein to avoid diminishing or destroying the historic significance of the Buildings or Facilities. There are exceptions to compliance with the FACBC for Qualified Historic Buildings and Facilities. Consult the SHPO for more information where indicated.

Project

Building

Location

Date

Surveyors

SHPO Contact Information :

Florida Department of State
Division of Historical Resources, Bureau of Historic Preservation
500 South Bronough St.
Tallahassee, Florida 32399

dos.myflorida.com/historical/preservation/architectural-services

850.245.6333

Priority 2 – Access to Goods & Services		Code Requirements	2014 Florida Accessibility Code Section No.	Possible Solutions
<p>2.1 Does the accessible <i>entrance</i> provide direct access to the main floor, lobby and elevator?</p> <p><input type="checkbox"/> Yes <input type="checkbox"/> No</p>			<p>202.5, 206.4 Exception 2</p> <p>**Consult SHPO**</p> <p>Photo #:</p>	<ul style="list-style-type: none"> • SHPO to evaluate and if no adverse impact to historic significance, <i>disproportionate costs</i> or technical infeasibility, create accessible route to the <i>maximum extent feasible</i>
Interior Accessible Route				
<p>2.2 Are all public spaces on at least one accessible route?</p> <p><input type="checkbox"/> Yes <input type="checkbox"/> No</p>			<p>202.5, 206.2.1 Exception 2</p> <p>**Consult SHPO**</p> <p>Photo #:</p>	<ul style="list-style-type: none"> • SHPO to evaluate and if no adverse impact to historic significance, <i>disproportionate costs</i> or technical infeasibility, create accessible route to the <i>maximum extent feasible</i>
<p>2.3 Is the route stable, firm and slip-resistant?</p> <p><input type="checkbox"/> Yes <input type="checkbox"/> No</p>			<p>302.1</p> <p>Photo #:</p>	<ul style="list-style-type: none"> • Repair uneven surfaces
<p>2.4 Is the route at least 36 inches wide?</p> <p>Note: The accessible route can narrow to 32 inches min. for a max. Of 24 inches. These narrower portions of the route must be at least 48 inches from each other.</p> <p>Measurement:</p>			<p>202.5, 403.5.1</p> <p>**Consult SHPO**</p> <p>Photo #:</p>	<ul style="list-style-type: none"> • SHPO to evaluate and if no adverse impact to historic significance, <i>disproportionate costs</i> or technical infeasibility, widen route to the <i>maximum extent feasible</i> • Rearrange fixtures, furnishing and equipment as necessary

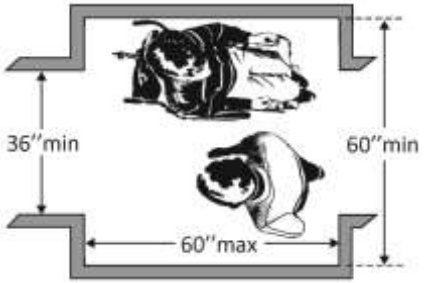
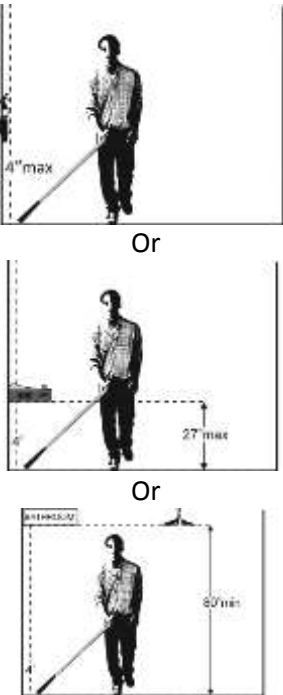
<p>2.5 If the route is greater than 200 feet in length and no less than 36 inches wide, is there a passing space no less than 60 x 60 inches?</p>	<p><input type="checkbox"/> Yes <input type="checkbox"/> No</p> <p>Measurement:</p>		<p>202.5, 403.5.3</p> <p>**Consult SHPO**</p> <p>Photo #:</p>	<ul style="list-style-type: none"> • SHPO to evaluate and if no adverse impact to historic significance, <i>disproportionate costs</i> or technical infeasibility, widen route for passing space to the <i>maximum extent feasible</i>
<p>2.6 Do all objects on circulation paths through public areas, e.g. fire extinguishers, drinking fountains, signs, etc. protrude no more than 4 inches into the path?</p> <p>Or</p> <p>If an object protrudes more than 4 inches, is the bottom leading edge at 27 inches or lower above the floor?</p> <p>Or</p> <p>Is the bottom leading edge at 80 inches or higher above the floor?</p>	<p><input type="checkbox"/> Yes <input type="checkbox"/> No</p> <p>Measurement:</p> <p><input type="checkbox"/> Yes <input type="checkbox"/> No</p> <p>Measurement:</p> <p><input type="checkbox"/> Yes <input type="checkbox"/> No</p> <p>Measurement:</p>		<p>307.2</p> <p>Photo #:</p>	<ul style="list-style-type: none"> • Remove object • Add tactile warning such as a cane detectable barrier, permanent planter or partial walls



<p>2.7 Are there elevators or platform lifts to all public stories?</p>	<p><input type="checkbox"/> Yes <input type="checkbox"/> No</p>		<p>202.3 (with Exceptions), 202.4 And 202.5</p> <p>**Consult SHPO**</p> <p>Photo #:</p>	<ul style="list-style-type: none"> • SHPO to evaluate and if no adverse impact to historic significance, general exception <i>disproportionate costs</i> or, technical infeasibility, vertical access to all levels above and below grade level shall be provided to the <i>maximum extent feasible</i> • Provide alternative methods of compliance as permitted by code that would provide a minimal level of access • Offer goods and services on an accessible story
--	---	--	--	--

Ramps – See Priority 1 Approach and Entrance Items 1.25 – 1.36 for Ramp Elements

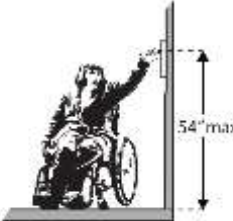
Elevators – Full Size & LULA (limited use, limited application) Note: LULA elevators are often used in *alterations*.

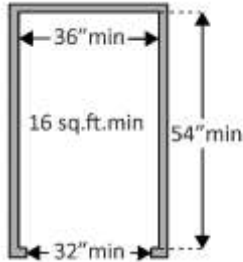
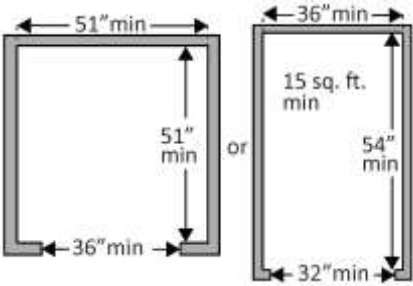
<p>2.8 If there is a full size or LULA elevator, are the call buttons no higher than 54 inches above the floor?</p>	<p><input type="checkbox"/> Yes <input type="checkbox"/> No</p> <p>Measurement:</p>		<p>407.2.1.1 (Exception)</p> <p>Photo #:</p>	<ul style="list-style-type: none"> • Change call button height
<p>2.9 If there is a full size or LULA elevator, does the sliding door reopen automatically when obstructed by an object or person? (Excluding manually operated doors)</p>	<p><input type="checkbox"/> Yes <input type="checkbox"/> No</p>		<p>407.3.3</p> <p>Photo #:</p>	<ul style="list-style-type: none"> • Install reopening device complying with 407.3.3

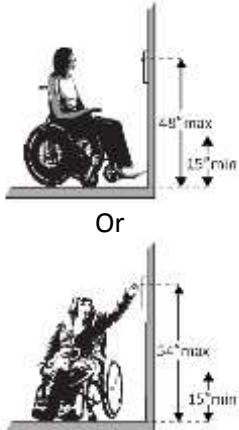
<p>2.10 If there is a LULA elevator with a swinging door:</p> <p>Is the door power- operated? <input type="checkbox"/> Yes <input type="checkbox"/> No</p> <p>Does the door remain open for at least 20 seconds when activated? <input type="checkbox"/> Yes <input type="checkbox"/> No</p> <p>Time:</p>			<p>408.3.2.1, 408.3.2.2</p> <p>Photo #:</p>	<ul style="list-style-type: none"> • Add power operated door • Adjust opening time
<p>2.11 If there is a full size elevator:</p> <p>Is the interior at least 54 inches deep by at least 36 inches wide with at least 16 sq. ft. of clear floor area? <input type="checkbox"/> Yes <input type="checkbox"/> No</p> <p>Measurement:</p> <p>Is the door opening width at least 32 inches? <input type="checkbox"/> Yes <input type="checkbox"/> No</p> <p>Measurement:</p>			<p>202.5, 404.2.3, 407.4.1 Exception, 407.3.6 Exception</p> <p>**Consult SHPO**</p> <p>Photo #:</p>	<ul style="list-style-type: none"> • SHPO to evaluate and if no adverse impact to historic significance, general exception <i>disproportionate costs</i> or, technical infeasibility, replace elevator
<p>2.12 If there is a LULA elevator, is the interior:</p> <p><input type="checkbox"/> Yes <input type="checkbox"/> No</p> <p>Measurement:</p> <p>At least 51 x 51 inches with a door opening width of at least 36 inches? Or At least 54 inches deep by at least 36 inches wide with at least 15 sq. ft. of clear floor area and a door opening width of at least 32 inches?</p> <p><input type="checkbox"/> Yes <input type="checkbox"/> No</p> <p>Measurement:</p>			<p>202.5, 408.4.1 Exception</p> <p>**Consult SHPO**</p> <p>Photo #:</p>	<ul style="list-style-type: none"> • SHPO to evaluate and if no adverse impact to historic significance, general exception <i>disproportionate costs</i> or, technical infeasibility, replace elevator

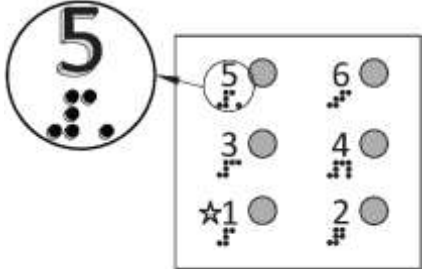
<p>2.13 If there is a full size or LULA elevator, are the in-car controls:</p> <p>No less than 15 inches and no greater 48 inches above the floor?</p> <p>Or</p> <p>Up to 54 inches above the floor for a parallel approach?</p>	<p><input type="checkbox"/> Yes <input type="checkbox"/> No</p> <p>Measurement:</p> <p><input type="checkbox"/> Yes <input type="checkbox"/> No</p> <p>Measurement:</p>		<p>308, 407.4.6.1</p> <p>Photo #:</p>	<ul style="list-style-type: none"> • Change control height
<p>2.14 If there is a LULA elevator, are the in-car controls centered on a side wall?</p>	<p><input type="checkbox"/> Yes <input type="checkbox"/> No</p> <p>Measurement:</p>		<p>408.4.6</p> <p>Photo #:</p>	<ul style="list-style-type: none"> • Reconfigure controls
<p>2.15 If there is a full size or LULA elevator:</p> <p>Are the car control buttons designated with raised characters?</p> <p>Are the car control buttons designated with Braille?</p>	<p><input type="checkbox"/> Yes <input type="checkbox"/> No</p> <p><input type="checkbox"/> Yes <input type="checkbox"/> No</p>		<p>407.4.7.1.2</p> <p>Photo #:</p>	<ul style="list-style-type: none"> • Add raised characters • Add Braille

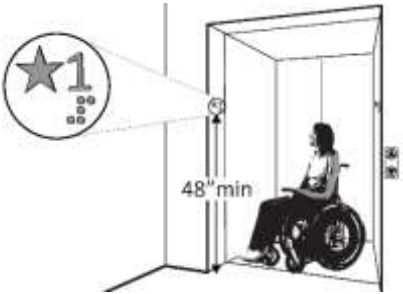
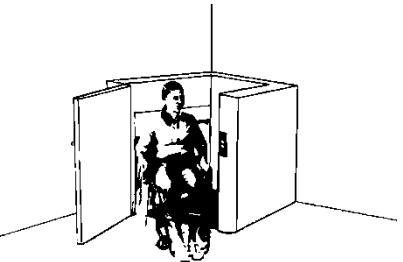
<p>2.16 If there is a full size or LULA elevator, are there audible signals which sound as the car passes or is about to stop at a floor?</p>	<p><input type="checkbox"/> Yes <input type="checkbox"/> No</p>		<p>407.4.8.2.1</p> <p>Photo #:</p>	<ul style="list-style-type: none"> • Install audible signals
<p>2.17 If there is a full size or LULA elevator:</p> <p>Is there a sign on both door jambs at every floor identifying the floor?</p> <p>Is there a tactile star on both jambs at the main entry level?</p> <p>Do text characters contrast with their backgrounds?</p> <p>Are text characters raised?</p> <p>Is there Braille?</p> <p>Is the sign mounted between 48 inches to the baseline of the lowest character and 60 inches to the baseline of the highest character above the floor?*</p>	<p><input type="checkbox"/> Yes <input type="checkbox"/> No</p> <p><input type="checkbox"/> Yes <input type="checkbox"/> No</p> <p><input type="checkbox"/> Yes <input type="checkbox"/> No</p> <p><input type="checkbox"/> Yes <input type="checkbox"/> No</p> <p><input type="checkbox"/> Yes <input type="checkbox"/> No</p> <p><input type="checkbox"/> Yes <input type="checkbox"/> No</p> <p>Measurement:</p>		<p>407.2.3.1, 703.4.1</p> <p>Photo #:</p>	<ul style="list-style-type: none"> • Install signs • Change sign height
<p>Platform Lifts</p>				
<p>2.18 If a lift is provided, can it be used without assistance from others?</p>	<p><input type="checkbox"/> Yes <input type="checkbox"/> No</p>		<p>410.1</p> <p>Photo #:</p>	<ul style="list-style-type: none"> • Reconfigure so independently operable

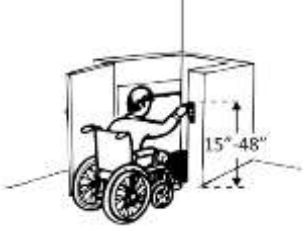
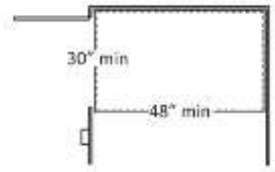
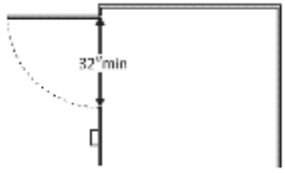
<p>2.19 Is there a clear floor space at least 30 inches wide by at least 48 inches long for a person using a wheelchair to approach and reach the controls to use the lift?</p>	<p><input type="checkbox"/> Yes <input type="checkbox"/> No Measurement:</p>		<p>305.3, 305.5, 410.3 Photo #:</p>	<ul style="list-style-type: none"> • Remove obstructions
<p>2.20 Are the lift controls no less than 15 inches and no greater than 48 inches above the floor?</p>	<p><input type="checkbox"/> Yes <input type="checkbox"/> No Measurement:</p>		<p>308, 410.5 Photo #:</p>	<ul style="list-style-type: none"> • Change control height
<p>2.21 Is there a clear floor space at least 30 inches wide by at least 48 inches long inside the lift?</p>	<p><input type="checkbox"/> Yes <input type="checkbox"/> No Measurement:</p>		<p>305.3, 410.3 Photo #:</p>	<ul style="list-style-type: none"> • Replace lift
<p>2.22 If there is an end door, is the clear opening width at least 32 inches?</p>	<p><input type="checkbox"/> Yes <input type="checkbox"/> No Measurement:</p>		<p>410.6 Photo #:</p>	<ul style="list-style-type: none"> • Alter door width

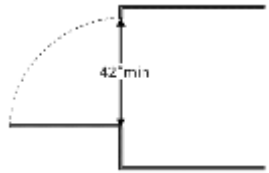
<p>2.23 If there is a side door, is the clear opening width at least 42 inches?</p>	<p><input type="checkbox"/> Yes <input type="checkbox"/> No</p> <p>Measurement:</p>		<p>410.6</p> <p>Photo #:</p>	<ul style="list-style-type: none"> • Alter door width
--	---	--	------------------------------	--

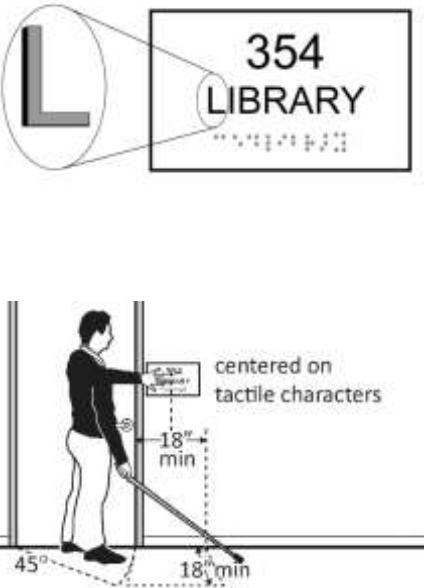
<p>Signs</p>		<p>Note: "Tactile characters" are read using touch, i.e. raised characters and Braille.</p>		
<p>2.24 If there are signs designating permanent rooms and spaces not likely to change over time, e.g. room numbers and letters, room names, and exit signs:</p> <p>Do text characters contrast with their backgrounds?</p> <p>Are text characters raised?</p> <p>Is there Braille?</p> <p>Is the sign mounted: On the wall on the latch side of the door?</p> <p>With clear floor space beyond the arc of the door swing between the closed position and 45-degree open position, at least 18 x 18 inches centered on the tactile characters?</p>	<p><input type="checkbox"/> Yes <input type="checkbox"/> No</p> <p><input type="checkbox"/> Yes <input type="checkbox"/> No</p> <p><input type="checkbox"/> Yes <input type="checkbox"/> No</p> <p><input type="checkbox"/> Yes <input type="checkbox"/> No</p> <p><input type="checkbox"/> Yes <input type="checkbox"/> No</p> <p>Measurement:</p>		<p>703.2, 703.4.1, 703.4.2, 703.5.1</p>	<ul style="list-style-type: none"> • Install tactile sign • Relocate sign <p>Notes: Signs are permitted on the push side of doors with closers and without hold-open devices.</p> <p>If the sign is at double doors with one active leaf, the sign should be on the inactive leaf; if both leaves are active, the sign should be on the wall to the right of the right leaf.</p>

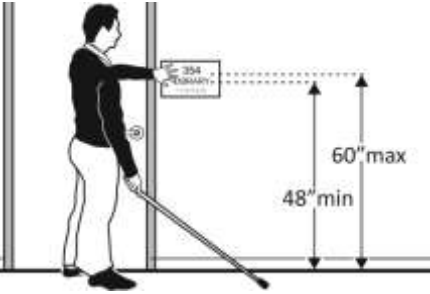
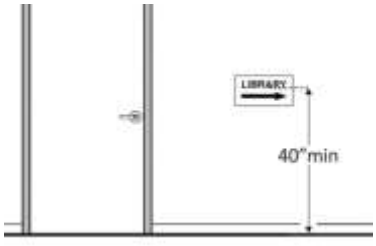
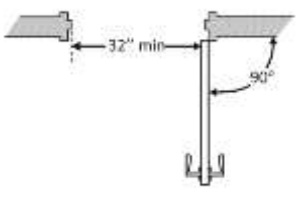
<p>Is the baseline of the lowest character is at least 48 inches above the floor and the baseline of the highest character is no more than 60 inches above the floor?</p>	<p><input type="checkbox"/> Yes <input type="checkbox"/> No</p> <p>Measurement:</p>		<p>Photo #:</p>	
<p>2.25 If there are signs that provide direction to or information about interior spaces:</p> <p>Do text characters contrast with their backgrounds?</p> <p>Is the sign mounted so that characters are at least 40 inches above the floor?</p>	<p><input type="checkbox"/> Yes <input type="checkbox"/> No</p> <p><input type="checkbox"/> Yes <input type="checkbox"/> No</p> <p>Measurement:</p>		<p>703.5.1, 703.5.6</p> <p>Photo #:</p>	<ul style="list-style-type: none"> • Install signs with contrasting characters • Change sign height <p>Raised characters and Braille are not required</p>
<p>Interior Doors</p>				
<p>2.26 Is the door opening width at least 32 inches clear, between the face of the door and the stop, when the door is open 90 degrees?</p>	<p><input type="checkbox"/> Yes <input type="checkbox"/> No</p> <p>Measurement:</p>		<p>202.5, 404.2.3</p> <p>**Consult SHPO**</p> <p>Photo #:</p>	<ul style="list-style-type: none"> • SHPO to evaluate and if no adverse impact to historic significance, <i>disproportionate costs</i> or technical infeasibility, alter doors to make them accessible to the <i>maximum extent feasible</i> • Install offset hinges

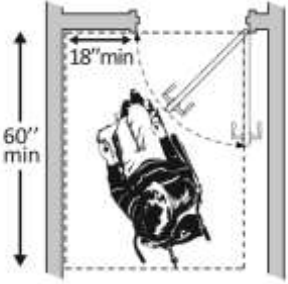

<p>2.27 If there is a front approach to the pull side of the door, is there at least 18 inches of maneuvering clearance beyond the latch side plus at least 60 inches clear depth?</p> <p>On both sides of the door, is the floor surface of the maneuvering clearance level (no steeper than 1:48)?</p>	<p><input type="checkbox"/> Yes <input type="checkbox"/> No</p> <p>Measurement:</p> <p><input type="checkbox"/> Yes <input type="checkbox"/> No</p> <p>Measurement:</p>		<p>202.5, 404.2.4.1, 404.2.4.4</p> <p>**Consult SHPO**</p> <p>Photo #:</p>	<ul style="list-style-type: none"> • SHPO to evaluate and if no adverse impact to historic significance, <i>disproportionate costs</i> or technical infeasibility, remove obstructions reconfigure walls to the <i>maximum extent feasible</i> or add an automatic door opener <p>See FACBC Section 404.2.4 for maneuvering clearance requirements</p>
---	---	--	---	---

Door Hardware See Priority 1 Approach and Entrance Items 1.44 – 1.47 for Door Hardware and Thresholds

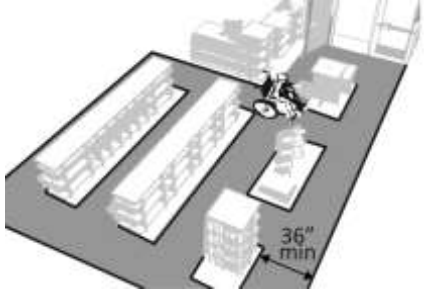
Rooms and Spaces

<p>2.28 Are aisles and pathways to goods and services, and to one of each type of sales and service counters, at least 36 inches wide?</p>	<p><input type="checkbox"/> Yes <input type="checkbox"/> No</p> <p>Measurement:</p>		<p>403.5.1</p> <p>Photo #:</p>	<ul style="list-style-type: none"> • Rearrange goods, equipment and furniture
---	---	---	--------------------------------	--

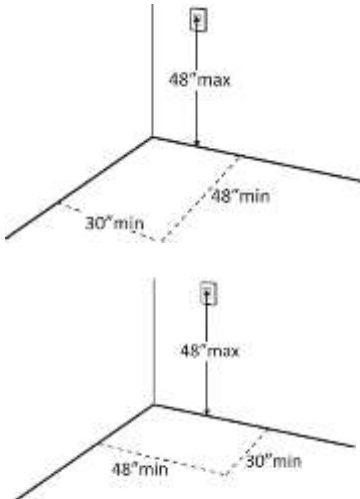

<p>2.29 Are floor surfaces stable, firm and slip resistant?</p>	<p><input type="checkbox"/> Yes <input type="checkbox"/> No</p>		<p>302.1</p> <p>Photo #:</p>	<ul style="list-style-type: none"> • Change floor surface
--	---	--	------------------------------	--

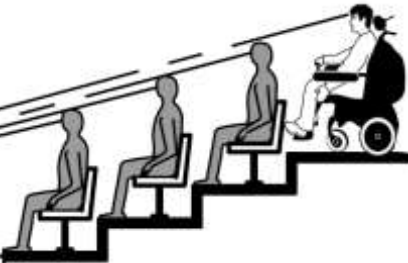
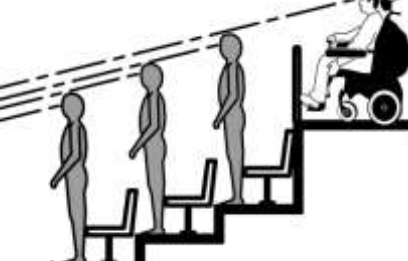
<p>2.30 If there is carpet:</p> <p>Is it no higher than ½ inch? <input type="checkbox"/> Yes <input type="checkbox"/> No</p> <p>Measurement:</p> <p>Is it securely attached along the edges? <input type="checkbox"/> Yes <input type="checkbox"/> No</p>	<p><input type="checkbox"/> Yes <input type="checkbox"/> No</p> <p>Measurement:</p> <p><input type="checkbox"/> Yes <input type="checkbox"/> No</p>		<p>302.2</p> <p>Photo #:</p>	<ul style="list-style-type: none"> • Replace carpet
<p>Controls – light switches, security and intercom systems, emergency/alarm boxes, etc.</p>				
<p>2.31 Is there a clear floor space at least 30 inches wide by at least 48 inches long for a forward or parallel approach?</p> <p>Are the operable parts no higher than 48 inches above the floor?*</p>	<p><input type="checkbox"/> Yes <input type="checkbox"/> No</p> <p>Measurement:</p> <p><input type="checkbox"/> Yes <input type="checkbox"/> No</p> <p>Measurement:</p>		<p>305.3, 308</p> <p>Photo #:</p>	<ul style="list-style-type: none"> • Change height of control
<p>2.32 Can the control be operated with one hand and without tight grasping, pinching, or twisting of the wrist?</p>	<p><input type="checkbox"/> Yes <input type="checkbox"/> No</p>		<p>309.4</p> <p>Photo #:</p>	<ul style="list-style-type: none"> • Replace control

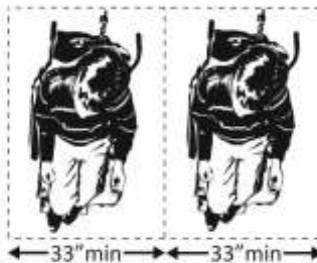
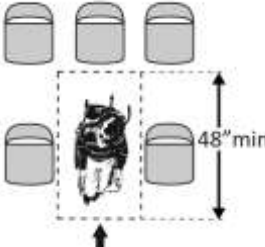
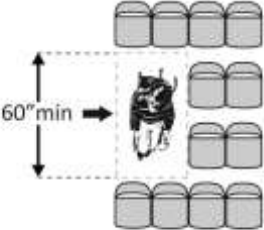
Seating: Assembly Areas – theaters, auditoriums, stadiums, theater style classrooms, etc.																
<p>2.33 Are an adequate number of wheelchair spaces provided?</p>	<p><input type="checkbox"/> Yes <input type="checkbox"/> No</p>	<table border="1"> <thead> <tr> <th># of Seats</th> <th>Wheelchair Spaces</th> </tr> </thead> <tbody> <tr> <td>4 - 25</td> <td>1</td> </tr> <tr> <td>26 - 50</td> <td>2</td> </tr> <tr> <td>51 - 150</td> <td>4</td> </tr> <tr> <td>151 - 300</td> <td>5</td> </tr> <tr> <td colspan="2">300+ see 2010 Standards 221.2.1.</td> </tr> </tbody> </table>	# of Seats	Wheelchair Spaces	4 - 25	1	26 - 50	2	51 - 150	4	151 - 300	5	300+ see 2010 Standards 221.2.1.		<p>221.2.1.1</p> <p>Photo #:</p>	<ul style="list-style-type: none"> • Reconfigure to add wheelchair spaces
# of Seats	Wheelchair Spaces															
4 - 25	1															
26 - 50	2															
51 - 150	4															
151 - 300	5															
300+ see 2010 Standards 221.2.1.																
<p>2.34 Are wheelchair spaces dispersed to allow location choices and viewing angles equivalent to other seating, including specialty seating areas that provide distinct services and amenities?</p>	<p><input type="checkbox"/> Yes <input type="checkbox"/> No</p>		<p>221.2.3</p> <p>Photo #:</p>	<ul style="list-style-type: none"> • Reconfigure to disperse wheelchair spaces 												
<p>2.35 Where people are expected to remain seated, do people in wheelchair spaces have a clear line of sight over and between the heads of others in front of them?</p>	<p><input type="checkbox"/> Yes <input type="checkbox"/> No</p>		<p>802.2.1.1, 802.2.1.2</p> <p>Photo #:</p>	<ul style="list-style-type: none"> • Alter for line of sight 												
<p>2.36 Where people are expected to stand, do people in wheelchair spaces have a clear line of sight over and between the heads of others in front of them?</p>	<p><input type="checkbox"/> Yes <input type="checkbox"/> No</p>		<p>802.2.2.1</p> <p>Photo #:</p>	<ul style="list-style-type: none"> • Alter for line of sight 												

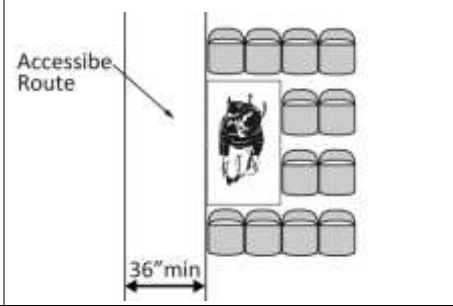
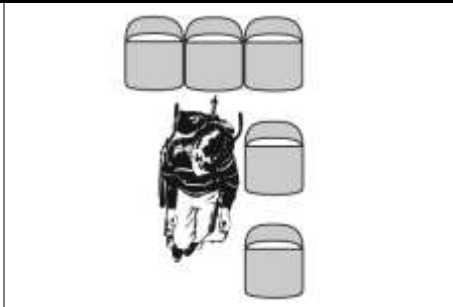
<p>2.37 If there is a single wheelchair space, is it at least 36 inches wide?</p>	<p><input type="checkbox"/> Yes <input type="checkbox"/> No</p> <p>Measurement:</p>		<p>802.1.2</p> <p>Photo #:</p>	<ul style="list-style-type: none"> • Alter space
<p>2.38 If there are two adjacent wheelchair spaces, are they each at least 33 inches wide?</p>	<p><input type="checkbox"/> Yes <input type="checkbox"/> No</p> <p>Measurement:</p>		<p>802.1.2</p> <p>Photo #:</p>	<ul style="list-style-type: none"> • Alter spaces
<p>2.39 If the wheelchair space can be entered from the front or rear, is it at least 48 inches deep?</p>	<p><input type="checkbox"/> Yes <input type="checkbox"/> No</p> <p>Measurement:</p>		<p>802.1.3</p> <p>Photo #:</p>	<ul style="list-style-type: none"> • Alter space
<p>2.40 If the wheelchair space can only be entered from the side, is it at least 60 inches deep?</p>	<p><input type="checkbox"/> Yes <input type="checkbox"/> No</p> <p>Measurement:</p>		<p>802.1.3</p> <p>Photo #:</p>	<ul style="list-style-type: none"> • Alter space

<p>2.41 Do wheelchair spaces adjoin, but not overlap, accessible routes?</p>	<input type="checkbox"/> Yes <input type="checkbox"/> No		<p>802.1.4</p> <p>Photo #:</p>	<ul style="list-style-type: none"> • Alter spaces
<p>2.42 Is there at least one companion seat for each wheelchair space?</p>	<input type="checkbox"/> Yes <input type="checkbox"/> No		<p>802.3</p> <p>Photo #:</p>	<ul style="list-style-type: none"> • Add companion seats
<p>2.43 Is the companion seat located so the companion is shoulder-to-shoulder with the person in a wheelchair?</p>	<input type="checkbox"/> Yes <input type="checkbox"/> No		<p>802.3.1</p> <p>Photo #:</p>	<ul style="list-style-type: none"> • Alter seating
<p>2.44 Is the companion seat equivalent in size, quality, comfort and amenities to seating in the immediate area?</p>	<input type="checkbox"/> Yes <input type="checkbox"/> No		<p>802.3.2</p> <p>Photo #:</p>	<ul style="list-style-type: none"> • Add equivalent seating
<p>Seating: At dining surfaces (restaurants, cafeterias, bars, etc.) and non-employee work surfaces (libraries, conference rooms, etc.)</p>				
<p>2.45 Are at least 5%, but no fewer than one, of seating and standing spaces accessible for people who use wheelchairs?</p>	<input type="checkbox"/> Yes <input type="checkbox"/> No Total #: Wheelchair #:		<p>226.1</p> <p>Photo #:</p>	<ul style="list-style-type: none"> • Alter to provide accessible spaces

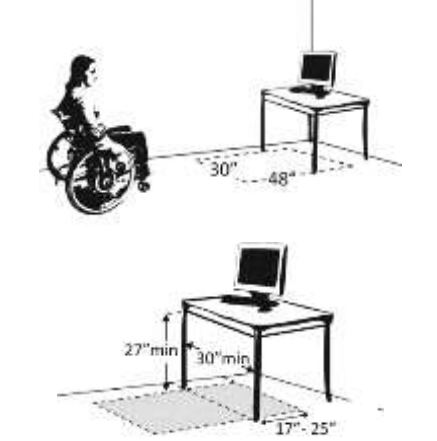
<p>2.46 Is there a route at least 36 inches wide to accessible seating?</p>	<p><input type="checkbox"/> Yes <input type="checkbox"/> No</p> <p>Measurement:</p>		<p>202.5, 403.5.1</p> <p>**Consult SHPO**</p> <p>Photo #:</p>	<ul style="list-style-type: none"> • SHPO to evaluate and if no adverse impact to historic significance, <i>disproportionate costs</i> or technical infeasibility, widen route to the <i>maximum extent feasible</i>
<p>2.47 At the accessible space(s), is the top of the accessible surface no less than 28 inches and no greater than 34 inches above the floor?</p>	<p><input type="checkbox"/> Yes <input type="checkbox"/> No</p> <p>Measurement:</p>		<p>902.3</p> <p>Photo #:</p>	<ul style="list-style-type: none"> • Alter surface height
<p>2.48 Is there a clear floor space at least 30 inches wide by at least 48 inches long for a forward approach?</p> <p>Does it extend no less than 17 inches and no greater than 25 inches under the surface?</p> <p>Is there knee space at least 27 inches high and at least 30 inches wide?</p>	<p><input type="checkbox"/> Yes <input type="checkbox"/> No</p> <p>Measurement:</p> <p><input type="checkbox"/> Yes <input type="checkbox"/> No</p> <p>Measurement:</p> <p><input type="checkbox"/> Yes <input type="checkbox"/> No</p> <p>Measurement:</p>		<p>305.5, 306.2.2, 306.2.3, 306.3.3, 306.3.5</p> <p>Photo #:</p>	<ul style="list-style-type: none"> • Alter table or work surface • Add accessible table or work surface

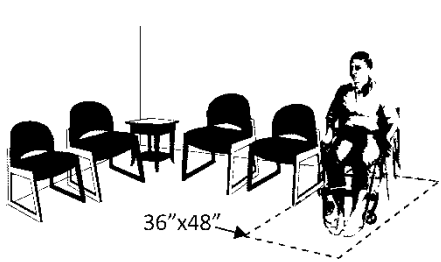
Seating: General – reception areas, waiting rooms, etc.				
<p>2.49 Is there at least one space at least 36 inches wide by at least 48 inches long for a person in a wheelchair?</p>	<input type="checkbox"/> Yes <input type="checkbox"/> No	Measurement:	 <p>A diagram illustrating a clear space for a wheelchair. A person in a wheelchair is positioned within a dashed rectangular area labeled "36''x48''". The space is situated around a table with four chairs, demonstrating the required clearances for wheelchair access.</p>	<p>802.1</p> <p>Photo #:</p> <ul style="list-style-type: none"> • Move furniture and equipment to provide space

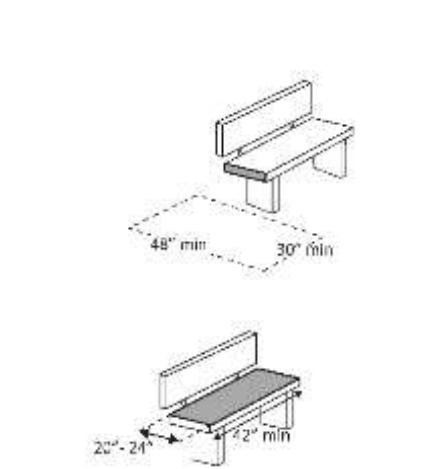
Benches				
<p>2.50 In locker rooms, dressing rooms and fitting rooms, is there at least one room with a bench?</p>	<input type="checkbox"/> Yes <input type="checkbox"/> No		<p>803.4</p> <p>Photo #:</p>	<ul style="list-style-type: none"> • Add bench
<p>2.51 Is there a clear floor space at least 30 inches wide by at least 48 inches long at the end of the bench and parallel to the short axis of the bench?</p> <p>Is the bench seat at least 42 inches long and no less than 20 inches and no greater than 24 inches deep?</p> <p>Does the bench have back support or is it affixed to a wall?</p>	<input type="checkbox"/> Yes <input type="checkbox"/> No	Measurement:	<p>305.3, 903.3, 903.4, 903.5</p>  <p>Two diagrams illustrating bench requirements. The top diagram shows a bench with a dashed rectangular area at its end labeled "48'' min" and "30'' min". The bottom diagram shows a side view of a bench with a dashed rectangular area at its end labeled "20''-24''" and "42'' min".</p>	<ul style="list-style-type: none"> • Move bench • Replace bench • Affix bench to wall

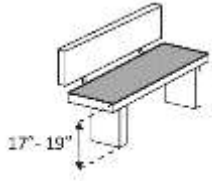

<p>Is the top of the bench seat no less than 17 inches and no greater than 19 inches above the floor?</p>	<p><input type="checkbox"/> Yes <input type="checkbox"/> No</p> <p>Measurement:</p>		<p>Photo #:</p>	
---	---	--	-----------------	--

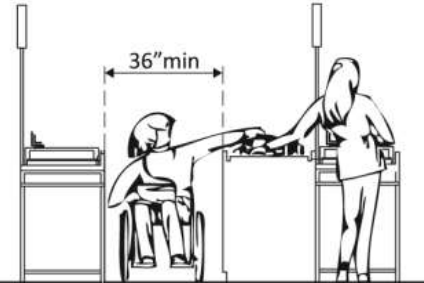
Check-Out Aisles

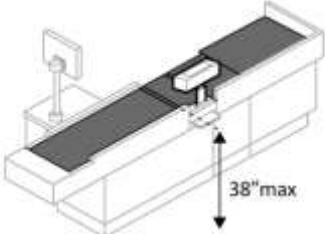
<p>2.52 Is the aisle at least 36 inches wide?</p>	<p><input type="checkbox"/> Yes <input type="checkbox"/> No</p> <p>Measurement:</p>		<p>403.5.1</p> <p>Photo #:</p>	<ul style="list-style-type: none"> • Widen aisle
--	---	--	--------------------------------	---

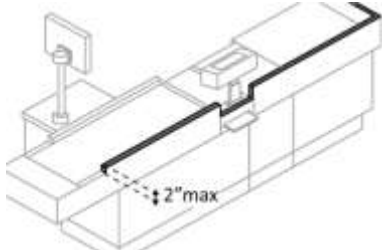
<p>2.53 Is the counter surface of at least one aisle no higher than 38 inches above the floor?</p>	<p><input type="checkbox"/> Yes <input type="checkbox"/> No</p> <p>Measurement:</p>		<p>904.3.2</p> <p>Photo #:</p>	<ul style="list-style-type: none"> • Lower counter
---	---	---	--------------------------------	---

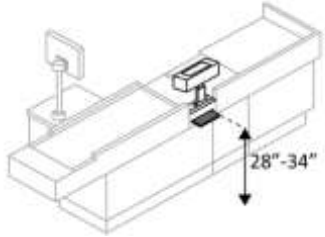
<p>2.54 Is the top of the counter edge protection no higher than 2 inches above the counter surface?</p>	<p><input type="checkbox"/> Yes <input type="checkbox"/> No</p> <p>Measurement:</p>		<p>904.3.2</p> <p>Photo #:</p>	<ul style="list-style-type: none"> • Lower edge protection
---	---	--	--------------------------------	---

<p>2.55 If there is a check writing surface, is the top no less than 28 inches and no greater than 34 inches above the floor?</p>	<p><input type="checkbox"/> Yes <input type="checkbox"/> No</p> <p>Measurement:</p>		<p>902.3, 904.3.3</p> <p>Photo #:</p>	<ul style="list-style-type: none"> • Alter check writing surface
<p>2.56 If there is more than one check-out aisle is there a sign with the Accessibility symbol at the accessible aisle?</p>	<p><input type="checkbox"/> Yes <input type="checkbox"/> No</p>		<p>216.11, 703.7.2.1</p> <p>Photo #:</p>	<ul style="list-style-type: none"> • Add sign

Sales & Service Counters

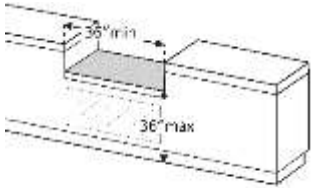
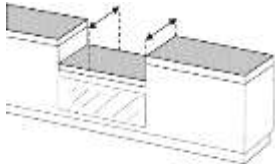
<p>2.57 Is there a portion of at least one of each type of counter that is:</p> <p>No higher than 36 inches above the floor?</p> <p>At least 36 inches long?</p>	<p><input type="checkbox"/> Yes <input type="checkbox"/> No</p> <p>Measurement:</p> <p><input type="checkbox"/> Yes <input type="checkbox"/> No</p> <p>Measurement:</p>		<p>904.4.1</p> <p>Photo #:</p>	<ul style="list-style-type: none"> • Lower section of counter • Lengthen section of counter per 904.4 (Exception)
<p>2.58 Does the accessible portion of the counter extend the same depth as the counter top?</p>	<p><input type="checkbox"/> Yes <input type="checkbox"/> No</p> <p>Measurement:</p>		<p>904.4</p> <p>Photo #:</p>	<ul style="list-style-type: none"> • Alter accessible portion

<p>2.59 Is there a clear floor space at least 30 inches wide by at least 48 inches long for a forward or parallel approach?</p>	<p><input type="checkbox"/> Yes <input type="checkbox"/> No</p> <p><input type="checkbox"/> Parallel Measurement:</p> <p><input type="checkbox"/> Forward Measurement:</p>		<p>305.3, 904.4.2</p> <p>Photo #:</p>	<ul style="list-style-type: none"> • Reconfigure to provide a parallel or forward approach
<p>2.60 For a parallel approach, is the clear floor space positioned with the 48 inches adjacent to the accessible length of counter?</p>	<p><input type="checkbox"/> Yes <input type="checkbox"/> No</p> <p>Measurement:</p>		<p>904.4.1</p> <p>Photo #:</p>	<ul style="list-style-type: none"> • If a parallel approach is not possible, a forward approach is required
<p>2.61 For a forward approach:</p> <p>Do no less than 17 and no greater than 25 inches of the clear floor space extend under the accessible length of the counter?</p> <p>Is there at least 27 inches clearance from the floor to the bottom of the counter?</p>	<p><input type="checkbox"/> Yes <input type="checkbox"/> No</p> <p>Measurement:</p> <p><input type="checkbox"/> Yes <input type="checkbox"/> No</p> <p>Measurement:</p>		<p>306.2, 306.3</p> <p>Photo #:</p>	<ul style="list-style-type: none"> • Reconfigure to provide knee clearance

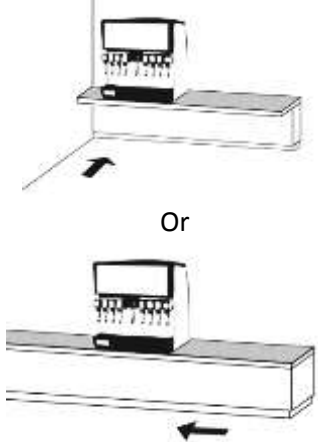
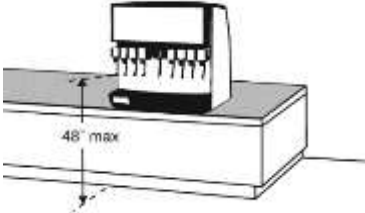
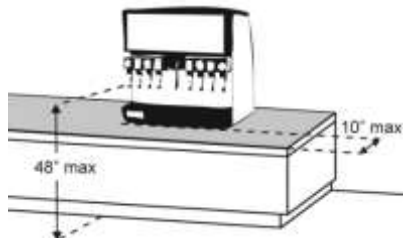
Food Service Lines				
<p>2.62 Does at least one of each type of self-service shelf or dispensing device for tableware, dishware, condiments, food and beverages have a forward or parallel approach?</p>	<p><input type="checkbox"/> Yes <input type="checkbox"/> No</p> <p><input type="checkbox"/> Forward</p> <p><input type="checkbox"/> Parallel</p>	 <p style="text-align: center;">Or</p>	<p>227.4</p> <p>Photo #:</p>	<ul style="list-style-type: none"> • Reconfigure to provide approach
<p>2.63 If there is an unobstructed parallel approach, is the shelf or dispensing device no higher than 48 inches above the floor?</p>	<p><input type="checkbox"/> Yes <input type="checkbox"/> No</p> <p>Measurement:</p>		<p>308.3.1</p> <p>Photo #:</p>	<ul style="list-style-type: none"> • Lower shelf and/or dispensing device
<p>2.64 If there is a shallow obstruction no deeper than 10 inches with a parallel approach, is the shelf or dispensing device no higher than 48 inches above the floor?</p>	<p><input type="checkbox"/> Yes <input type="checkbox"/> No</p> <p>Measurement:</p>		<p>308.3.1 (Exception 1)</p> <p>Photo #:</p>	<ul style="list-style-type: none"> • Lower shelf and/or dispensing device

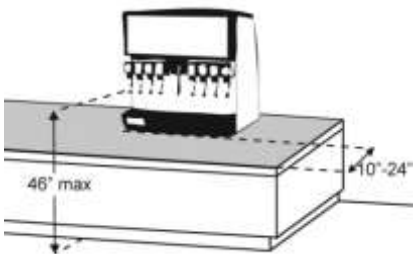
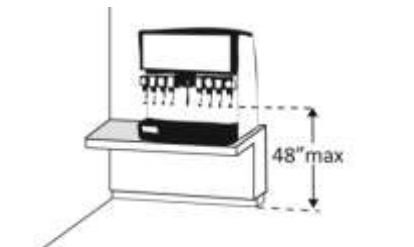
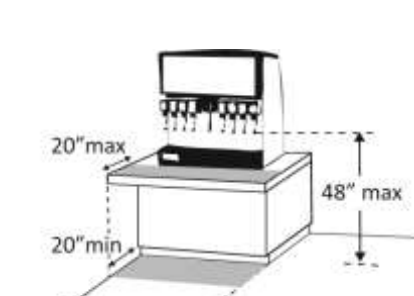
<p>2.65 If there is an obstruction no less than 10 inches and no greater than 24 inches deep with a parallel approach, is the shelf or dispensing device no higher than 46 inches above the floor?</p>	<p><input type="checkbox"/> Yes <input type="checkbox"/> No</p> <p>Measurement:</p>		<p>308.3.2</p> <p>Photo #:</p>	<ul style="list-style-type: none"> • Lower shelf and/or dispensing device
<p>2.66 If there is an unobstructed forward approach, is the shelf or dispensing device no higher than 48 inches above the floor?</p>	<p><input type="checkbox"/> Yes <input type="checkbox"/> No</p> <p>Measurement:</p>		<p>308.2.1</p> <p>Photo #:</p>	<ul style="list-style-type: none"> • Lower shelf and/or dispensing device
<p>2.67 If there is an obstruction no deeper than 20 inches with a forward approach:</p> <p>Does clear floor space extend under the obstruction that is at least the same depth as the obstruction?</p> <p>Is the shelf or dispensing device no higher than 48 inches above the floor?</p>	<p><input type="checkbox"/> Yes <input type="checkbox"/> No</p> <p>Measurement:</p> <p><input type="checkbox"/> Yes <input type="checkbox"/> No</p> <p>Measurement:</p>		<p>308.2.2</p> <p>Photo #:</p>	<ul style="list-style-type: none"> • Reconfigure to provide knee space • Lower shelf and/or dispensing device

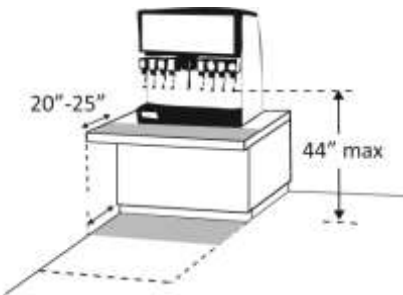
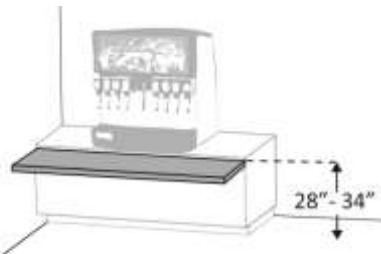
<p>2.68 If the obstruction is no less than 20 inches and no greater than 25 inches deep with a forward approach:</p> <p>Does clear floor space extend under the obstruction that is at least the same depth as the obstruction?</p> <p>Is the shelf or dispensing device no higher than 44 inches above the floor?</p>	<p><input type="checkbox"/> Yes <input type="checkbox"/> No</p> <p>Measurement:</p> <p><input type="checkbox"/> Yes <input type="checkbox"/> No</p> <p>Measurement:</p>		<p>308.2.2</p> <p>Photo #:</p>	<ul style="list-style-type: none"> • Reconfigure to provide knee space • Lower shelf and/or dispensing device
<p>2.69 If there is a tray slide, is the top no less than 28 inches and no greater than 34 inches above the floor?</p>	<p><input type="checkbox"/> Yes <input type="checkbox"/> No</p> <p>Measurement:</p>		<p>904.5.2</p> <p>Photo #:</p>	<ul style="list-style-type: none"> • Reconfigure

The ADA Checklist for Readily Achievable Barrier Removal

Priority 3 - Toilet Rooms

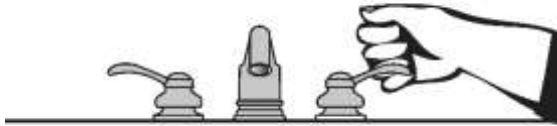

Project

Building

Location

Date

Surveyors



SHPO Contact Information :

Florida Department of State
Division of Historical Resources, Bureau of Historic Preservation
500 South Bronough St.
Tallahassee, Florida 32399

dos.myflorida.com/historical/preservation/architectural-services

850.245.6333

NOTE: Alterations to Qualified Historic Buildings and Facilities shall comply with the Florida Accessibility Code for Building Construction (FACBC) to the *maximum extent feasible*. All proposed changes to achieve *compliance* with the FACBC should be reviewed by the State Historic Preservation Officer (SHPO) prior to undertaking any required or suggested corrective measures described herein to avoid diminishing or destroying the historic significance of the Buildings or Facilities. There are exceptions to compliance with the FACBC for Qualified Historic Buildings and Facilities. Consult the SHPO for more information where indicated.

Priority 3 – Toilet Rooms		Code Requirements	2014 Florida Accessibility Code Section No.	Possible Solutions
<p>3.1 If toilet rooms are available to the public, is at least one toilet room accessible? (Either one for each sex, or one unisex.)</p> <p><input type="checkbox"/> Yes <input type="checkbox"/> No</p>			<p>202.4, 202.5, 213.2 Exception 2</p> <p>**Consult SHPO**</p> <p>Photo #:</p>	<ul style="list-style-type: none"> • SHPO to evaluate and if no adverse impact to historic significance, <i>disproportionate costs</i> or technical infeasibility, reconfigure toilet rooms or combine toilet rooms to create one unisex accessible toilet room
<p>3.2 Are there signs at inaccessible toilet rooms that give directions to accessible toilet rooms?</p> <p><input type="checkbox"/> Yes <input type="checkbox"/> No</p>			<p>216.8</p> <p>Photo #:</p>	<ul style="list-style-type: none"> • Install signs
<p>3.3 If not all toilet rooms are accessible, is there a sign at the accessible toilet room with the International Symbol of Accessibility?</p> <p><input type="checkbox"/> Yes <input type="checkbox"/> No</p>			<p>216.8, 703.7.2.1</p> <p>Photo #:</p>	<ul style="list-style-type: none"> • Install sign
Accessible Route				
<p>3.4 Is there a route to the accessible toilet room(s) that does not include the use of stairs?</p> <p><input type="checkbox"/> Yes <input type="checkbox"/> No</p> <p>Is the route accessible? (See Priority 2 Interior Accessible Route for specifics.)</p> <p><input type="checkbox"/> Yes <input type="checkbox"/> No</p>			<p>202.4, 202.5, 206.2.4, 213.1</p> <p>**Consult SHPO**</p> <p>Photo #:</p>	<ul style="list-style-type: none"> • SHPO to evaluate and if no adverse impact to historic significance, <i>disproportionate costs</i> or technical infeasibility, alter route or relocate toilet room(s)

Signs at Toilet Rooms

3.5 Do text characters contrast with their backgrounds?

Yes No

Are text characters raised?

Yes No

Is there Braille?

Yes No

Is the sign mounted:
On the wall on the latch side of the door?

Yes No

Note:
Signs are permitted on the push side of doors with closers and without hold-open devices.

With clear floor space beyond the arc of the door swing between the closed position and 45-degree open position, at least 18 x 18 inches centered on the tactile characters? *

Yes No

Measurement:

Is the baseline of the lowest character is at least 48 inches above the floor and the baseline of the highest character is no more than 60 inches above the floor? *

Yes No

Measurement:

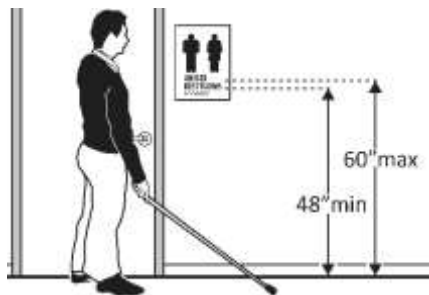
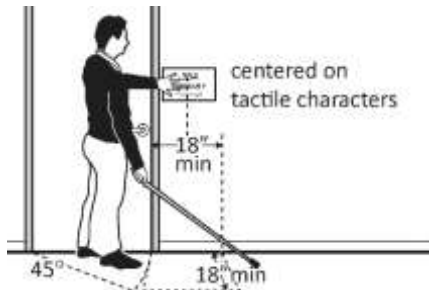
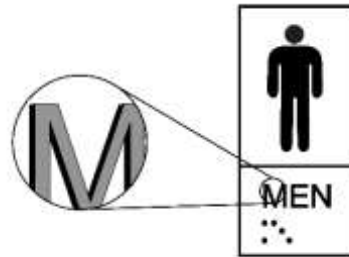

703.2, 703.4.1, 703.4.2, 703.5.1



- Install tactile sign
- Relocate sign

Note:
If the sign is at double doors with one active leaf, the sign should be on the inactive leaf; if both leaves are active, the sign should be on the wall to the right of the right leaf.

Photo #:

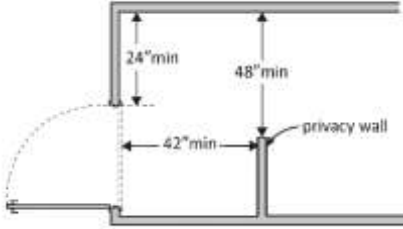
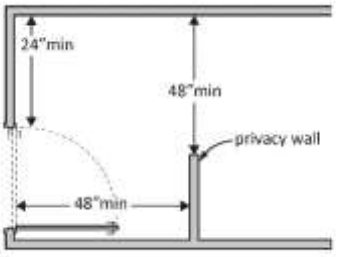

Entrance – See Priority 1 Sections 1.41 - 1.44

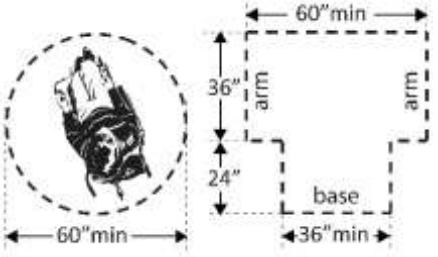
Door Hardware – See Priority 1 Sections 1.45 - 1.47

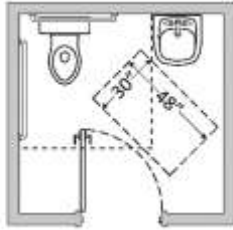
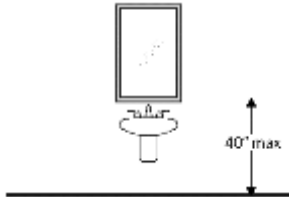
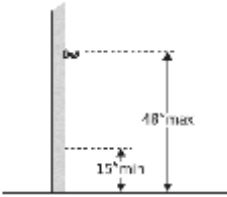

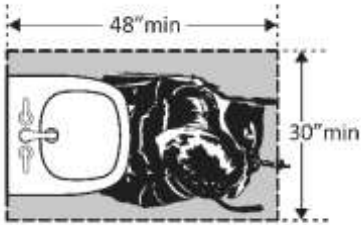
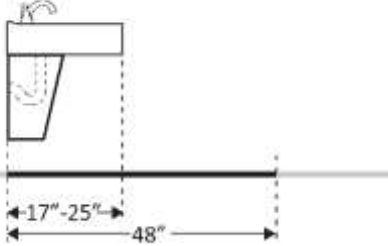
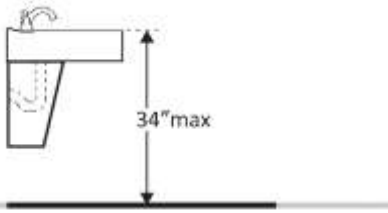
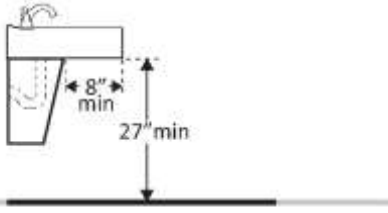
Vestibule Doors in a Series – See Priority 1 Section 1.48				
<p>3.6 If there is a privacy wall and the door swings out, is there at least 24 inches of maneuvering clearance beyond the door latch side and 42 inches to the privacy wall?</p>	<p><input type="checkbox"/> Yes <input type="checkbox"/> No</p> <p>Measurement:</p>		<p>404.2.4</p> <p>Photo #:</p>	<ul style="list-style-type: none"> • Reconfigure space
<p>3.7 If there is a privacy wall and the door swings in, is there at least 24 inches of maneuvering clearance beyond the door latch side and at least 48 inches to the privacy wall if there is no door closer or at least 54 inches if there is a door closer?</p>	<p><input type="checkbox"/> Yes <input type="checkbox"/> No</p> <p>Measurement:</p>		<p>404.2.4</p> <p>Photo #:</p>	<ul style="list-style-type: none"> • Reconfigure space
In the Toilet Room				
<p>3.8 Is there a clear path to at least one of each type of fixture, e.g. lavatory, hand dryer, etc., that is at least 36 inches wide?</p>	<p><input type="checkbox"/> Yes <input type="checkbox"/> No</p> <p>Measurement:</p>		<p>403.5.1</p> <p>Photo #:</p>	<ul style="list-style-type: none"> • Remove obstructions
<p>3.9 Is there clear floor space available for a person in a wheelchair to turn around, i.e. a circle at least 60 inches in diameter or a T-shaped space within a 60-inch square?*</p>	<p><input type="checkbox"/> Yes <input type="checkbox"/> No</p> <p>Measurement:</p>		<p>304.3</p> <p>Photo #:</p>	<ul style="list-style-type: none"> *The door to the toilet room may swing into the required turning space • Move or remove partitions, fixtures or objects such as trash cans

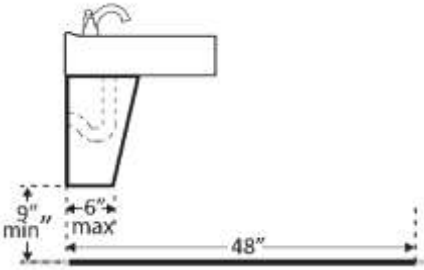
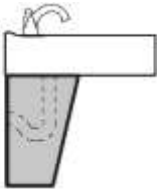
<p>3.10 In a single user toilet room if the door swings in and over a clear floor space at an accessible fixture, is there a clear floor space at least 30 x 48 inches beyond the swing of the door?</p>	<p><input type="checkbox"/> Yes <input type="checkbox"/> No Measurement:</p>		<p>603.2.3 Exception 2 Photo #:</p>	<ul style="list-style-type: none"> • Reverse door swing • Alter toilet room
<p>3.11 If the mirror is over a lavatory or countertop, is the bottom edge of the reflecting surface no higher than 40 inches above the floor? Or If the mirror is not over the lavatory or countertop, is the bottom edge of the reflecting surface no higher than 35 inches above the floor?*</p>	<p><input type="checkbox"/> Yes <input type="checkbox"/> No Measurement: <input type="checkbox"/> Yes <input type="checkbox"/> No Measurement:</p>		<p>603.3 Photo #:</p>	<ul style="list-style-type: none"> • Lower the mirror • Add another mirror
<p>3.12 If there is a coat hook, is it no less than 15 inches and no greater than 48 inches above the floor?</p>	<p><input type="checkbox"/> Yes <input type="checkbox"/> No Measurement:</p>		<p>308, 603.4 Photo #:</p>	<ul style="list-style-type: none"> • Adjust hook • Replace with or provide additional accessible hook

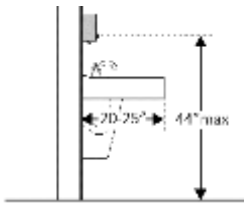

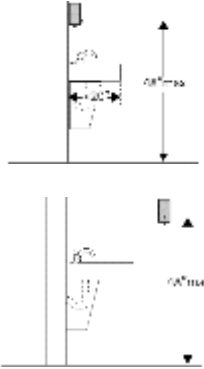
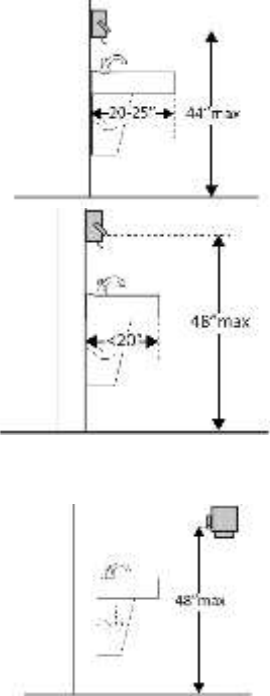
Lavatories				
<p>3.13 Does at least one lavatory have a clear floor space for a forward approach at least 30 inches wide and 48 inches long?</p>	<input type="checkbox"/> Yes <input type="checkbox"/> No	<p>Measurement:</p> 	<p>305.3, 606.2</p> <p>Photo #:</p>	<ul style="list-style-type: none"> • Alter lavatory • Replace lavatory
<p>3.14 Do no less than 17 inches and no greater than 25 inches of the clear floor space extend under the lavatory so that a person using a wheelchair can get close enough to reach the faucet?</p>	<input type="checkbox"/> Yes <input type="checkbox"/> No	<p>Measurement:</p> 	<p>306.2</p> <p>Photo #:</p>	<ul style="list-style-type: none"> • Alter lavatory • Replace lavatory
<p>3.15 Is the front of the lavatory or counter surface, whichever is higher, no more than 34 inches above the floor?</p>	<input type="checkbox"/> Yes <input type="checkbox"/> No	<p>Measurement:</p> 	<p>606.3</p> <p>Photo #:</p>	<ul style="list-style-type: none"> • Alter lavatory • Replace lavatory
<p>3.16 Is there at least 27 inches clearance from the floor to the bottom of the lavatory that extends at least 8 inches under the lava for knee clearance?</p>	<input type="checkbox"/> Yes <input type="checkbox"/> No	<p>Measurement:</p> 	<p>306.3</p> <p>Photo #:</p>	<ul style="list-style-type: none"> • Alter lavatory • Replace lavatory

<p>3.17 Is there toe clearance at least 9 inches high? (Space extending greater than 6 inches beyond the available toe clearance at 9 inches above the floor is not considered toe clearance.)</p>	<p><input type="checkbox"/> Yes <input type="checkbox"/> No</p>		<p>306.2</p> <p>Photo #:</p>	<ul style="list-style-type: none"> • Alter lavatory • Replace lavatory
<p>3.18 Are pipes below the lavatory insulated or otherwise configured to protect against contact?</p>	<p><input type="checkbox"/> Yes <input type="checkbox"/> No</p>		<p>606.5</p> <p>Photo #:</p>	<ul style="list-style-type: none"> • Install insulation • Install cover panel
<p>3.19 Can the faucet be operated without tight grasping, pinching, or twisting of the wrist?</p> <p>Is the force required to activate the faucet no greater than 5 pounds?</p>	<p><input type="checkbox"/> Yes <input type="checkbox"/> No</p> <p><input type="checkbox"/> Yes <input type="checkbox"/> No</p>		<p>309.4</p> <p>Photo #:</p>	<ul style="list-style-type: none"> • Adjust faucet • Replace faucet
<p>Soap Dispensers and Hand Dryers (2010 Standards – 603)</p>				
<p>3.20 Are the operable parts of the soap dispenser within one of the following reach ranges:</p> <p>Above lavatories or counters no less than 20 inches and no greater than 25 inches deep: no higher than 44 inches above the floor?</p>	<p><input type="checkbox"/> Yes <input type="checkbox"/> No</p> <p>Measurement:</p>		<p>308.2.2, 606.1</p>	<ul style="list-style-type: none"> • Adjust dispensers • Replace with or provide additional accessible dispensers

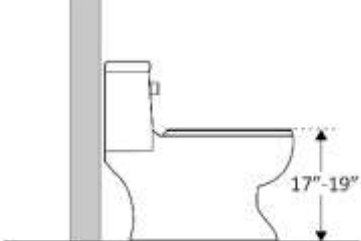
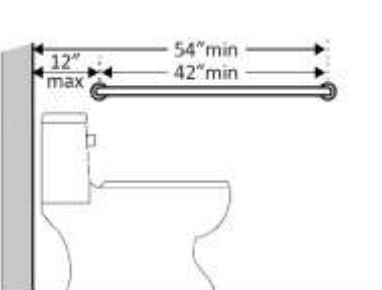
<p>Above lavatories less than 20 inches deep: no higher than 48 inches above the floor?</p> <p>Not over an obstruction: no higher than 48 inches above the floor?</p>	<p><input type="checkbox"/> Yes <input type="checkbox"/> No Measurement:</p> <p><input type="checkbox"/> Yes <input type="checkbox"/> No Measurement:</p>		<p>Photo #:</p>	
<p>3.21 Are the operable parts of the hand dryer or towel dispenser within one of the following reach ranges:</p> <p>Above lavatories or counters no less than 20 inches and no greater than 25 inches deep: no higher than 44 inches above the floor?</p> <p>Above lavatories less than 20 inches deep: no higher than 48 inches above the floor?</p> <p>Not over an obstruction: no higher than 48 inches above the floor?</p> <p>Can the operable parts of the hand dryer or towel dispenser be operated without tight grasping, pinching or twisting of the wrist?</p> <p>Is the force required to activate the hand dryer or towel dispenser no greater than 5 pounds?</p>	<p><input type="checkbox"/> Yes <input type="checkbox"/> No Measurement:</p> <p><input type="checkbox"/> Yes <input type="checkbox"/> No Measurement:</p> <p><input type="checkbox"/> Yes <input type="checkbox"/> No Measurement:</p> <p><input type="checkbox"/> Yes <input type="checkbox"/> No Measurement:</p> <p><input type="checkbox"/> Yes <input type="checkbox"/> No Measurement:</p>		<p>308.2.1, 308.2.2, 309.4, 606.1</p> <p>Photo #:</p>	<ul style="list-style-type: none"> • Adjust dispensers • Replace with or provide additional accessible dispensers

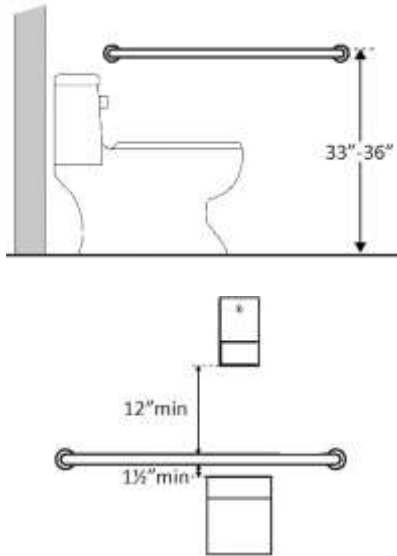
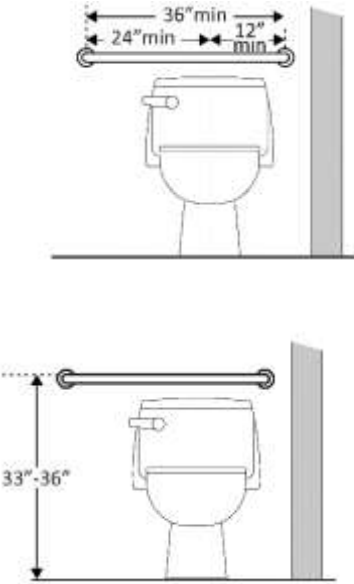
Water Closets in Single-User Toilet Rooms and Compartments (Stalls)				
<p>3.22 Is the centerline of the water closet no less than 16 inches and no greater than 18 inches from the side wall or partition?</p>	<p><input type="checkbox"/> Yes <input type="checkbox"/> No Measurement:</p>		<p>604.2 Photo #:</p>	<ul style="list-style-type: none"> • Move toilet • Replace toilet • Move partition
<p>3.23 Is clearance provided around the water closet measuring at least 60 inches from the side wall and at least 56 inches from the rear wall?*</p>	<p><input type="checkbox"/> Yes <input type="checkbox"/> No Measurement:</p>		<p>604.3.1 Photo #:</p>	<ul style="list-style-type: none"> • Alter room/compartment for clearance
<p>3.24 Is the height of the water closet no less than 17 inches and no greater than 19 inches above the floor measured to the top of the seat?</p>	<p><input type="checkbox"/> Yes <input type="checkbox"/> No Measurement:</p>		<p>604.4 Photo #:</p>	<ul style="list-style-type: none"> • Adjust toilet height • Replace toilet
<p>3.25 Is there a grab bar at least 42 inches long on the side wall?</p> <p>Is it located no more than 12 inches from the rear wall?</p> <p>Does it extend at least 54 inches from the rear wall?</p>	<p><input type="checkbox"/> Yes <input type="checkbox"/> No Measurement:</p> <p><input type="checkbox"/> Yes <input type="checkbox"/> No Measurement:</p> <p><input type="checkbox"/> Yes <input type="checkbox"/> No</p>		<p>604.5.1, 609.3, 609.4</p>	<ul style="list-style-type: none"> • Install grab bar • Relocate grab bar • Relocate objects

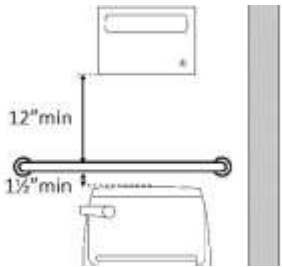
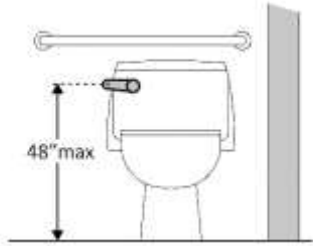
<p>Is it mounted no less than 33 inches and no greater than 36 inches above the floor to the top of the gripping surface?</p> <p>Is there at least 12 inches clearance between the grab bar and protruding objects above?*</p> <p>Is there at least 1½ inches clearance between the grab bar and projecting objects below?*</p> <p>Is the space between the wall and the grab bar 1 ½ inches?</p>	<p><input type="checkbox"/> Yes <input type="checkbox"/> No Measurement:</p> <p><input type="checkbox"/> Yes <input type="checkbox"/> No Measurement:</p> <p><input type="checkbox"/> Yes <input type="checkbox"/> No Measurement:</p> <p><input type="checkbox"/> Yes <input type="checkbox"/> No Measurement:</p>		<p>Photo #:</p>	<p>* If constructed before 3/15/2012 grab bars do not need to be relocated; there are no space requirements above and below grab bars in the 1991 Standards</p>
<p>3.26 Is there a grab bar at least 36 inches long on the rear wall?</p> <p>Does it extend at least 12 inches from the centerline of the water closet on one side (side wall)?</p> <p>Does it extend at least 24 inches on the other (open) side?</p> <p>Is it mounted no less than 33 inches and no greater than 36 inches above the floor to the top of the gripping surface?</p>	<p><input type="checkbox"/> Yes <input type="checkbox"/> No Measurement:</p> <p><input type="checkbox"/> Yes <input type="checkbox"/> No Measurement:</p> <p><input type="checkbox"/> Yes <input type="checkbox"/> No Measurement:</p> <p><input type="checkbox"/> Yes <input type="checkbox"/> No Measurement:</p>		<p>604.5.2, 609.3, 609.4</p>	<ul style="list-style-type: none"> • Install grab bar • Relocate grab bar • Relocate objects

<p>Are there at least 12 inches clearance between the grab bar and protruding objects above?*</p> <p>Are there at least 1½ inches clearance between the grab bar and projecting objects below?*</p> <p>Is the space between the wall and the grab bar 1 ½ inches?</p>	<p><input type="checkbox"/> Yes <input type="checkbox"/> No Measurement:</p> <p><input type="checkbox"/> Yes <input type="checkbox"/> No Measurement:</p> <p><input type="checkbox"/> Yes <input type="checkbox"/> No Measurement:</p>		<p>Photo #:</p>	
<p>3.27 If the flush control is hand operated, is the operable part located no higher than 48 inches above the floor?</p>	<p><input type="checkbox"/> Yes <input type="checkbox"/> No Measurement:</p>		<p>308, 309, 604.6</p> <p>Photo #:</p>	<ul style="list-style-type: none"> • Move control • Install sensor with override button no higher than 48 inches
<p>3.28 If the flush control is hand operated, can it be operated with one hand and without tight grasping, pinching, or twisting of the wrist?</p> <p>Is the force required to activate the flush control no greater than 5 pounds?</p>	<p><input type="checkbox"/> Yes <input type="checkbox"/> No Measurement:</p> <p><input type="checkbox"/> Yes <input type="checkbox"/> No Measurement:</p>		<p>309</p> <p>Photo #:</p>	<ul style="list-style-type: none"> • Change control • Adjust control

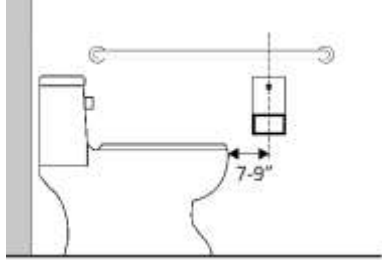
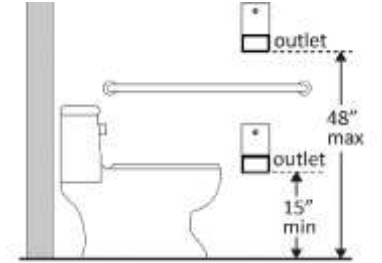
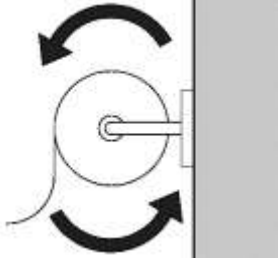
<p>3.29 Is the flush control on the open side of the water closet?</p>	<p><input type="checkbox"/> Yes <input type="checkbox"/> No</p>		<p>604.6</p>	<ul style="list-style-type: none"> • Move control
<p>3.30 Is the toilet paper dispenser located no less than 7 inches and no greater than 9 inches from the front of the water closet to the centerline of the dispenser?*</p>	<p><input type="checkbox"/> Yes <input type="checkbox"/> No Measurement:</p>		<p>604.7</p>	<ul style="list-style-type: none"> • Relocate dispenser
<p>3.31 Is the outlet of the dispenser: Located no less than 15 inches and no greater than 48 inches above the floor? Not located behind grab bars?</p>	<p><input type="checkbox"/> Yes <input type="checkbox"/> No Measurement: <input type="checkbox"/> Yes <input type="checkbox"/> No</p>		<p>604.7</p>	<ul style="list-style-type: none"> • Relocate dispenser
<p>3.32 Does the dispenser allow continuous paper flow?</p>	<p><input type="checkbox"/> Yes <input type="checkbox"/> No</p>		<p>604.7</p>	<ul style="list-style-type: none"> • Adjust dispenser • Replace dispenser

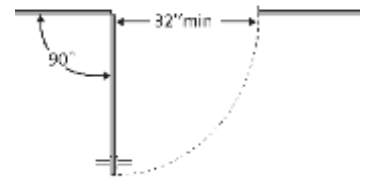
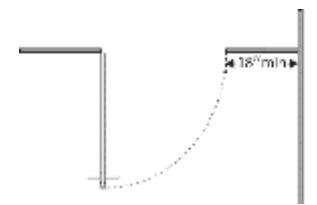
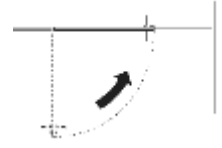
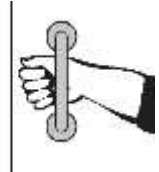
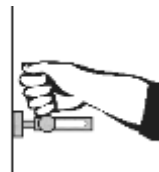
Toilet Compartments (Stalls)				
<p>3.33 Is the door opening width at least 32 inches clear, between the face of the door and the stop, when the door is open 90 degrees?</p>	<p><input type="checkbox"/> Yes <input type="checkbox"/> No</p> <p>Measurement:</p>		<p>404.2.3, 604.8.1.2</p> <p>Photo #:</p>	<ul style="list-style-type: none"> • Widen door width
<p>3.34 If there is a front approach to the pull side of the door, is there at least 18 inches of maneuvering clearance beyond the latch side plus 60 inches clear depth?*</p>	<p><input type="checkbox"/> Yes <input type="checkbox"/> No</p> <p>Measurement:</p>		<p>404.2.4.1, 604.8.1.2</p> <p>Photo #:</p>	<p>*See 604.8.1.2 Doors for maneuvering clearance requirements on the push side of the door and side approaches to the pull side of the door</p> <ul style="list-style-type: none"> • Remove obstructions
<p>3.35 Is the door self-closing?</p>	<p><input type="checkbox"/> Yes <input type="checkbox"/> No</p>		<p>604.8.1.2</p> <p>Photo #:</p>	<ul style="list-style-type: none"> • Add closer • Replace door
<p>3.36 Are there door pulls on both sides of the door that are operable with one hand and do not require tight grasping pinching or twisting of the wrist?*</p>	<p><input type="checkbox"/> Yes <input type="checkbox"/> No</p>		<p>309.4, 404.2.7, 604.8.1.2</p> <p>Photo #:</p>	<ul style="list-style-type: none"> • Replace hardware
<p>3.37 Is the lock operable with one hand and without tight grasping, pinching or twisting of the wrist?</p>	<p><input type="checkbox"/> Yes <input type="checkbox"/> No</p>		<p>309.4, 404.2.7, 604.8.1.2</p> <p>Photo #:</p>	<ul style="list-style-type: none"> • Replace lock

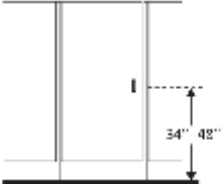
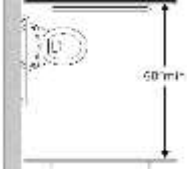
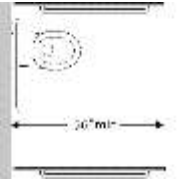
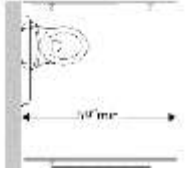
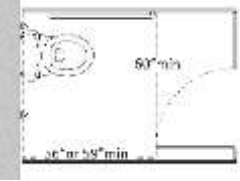
<p>3.38 Are the operable parts of the door hardware mounted no less than 34 inches and no greater than 48 inches above the floor?</p>	<p><input type="checkbox"/> Yes <input type="checkbox"/> No Measurement:</p>		<p>404.2.7, 604.8.1.2 Photo #:</p>	<ul style="list-style-type: none"> • Relocate hardware
<p>3.39 Is the compartment at least 60 inches wide?</p>	<p><input type="checkbox"/> Yes <input type="checkbox"/> No Measurement:</p>		<p>604.8.1.1 Photo #:</p>	<ul style="list-style-type: none"> • Widen compartment
<p>3.40 If the water closet is wall hung, is the compartment at least 56 inches deep?</p>	<p><input type="checkbox"/> Yes <input type="checkbox"/> No Measurement:</p>		<p>604.8.1.1 Photo #:</p>	<ul style="list-style-type: none"> • Widen compartment
<p>3.41 If the water closet is floor mounted, is the compartment at least 59 inches deep?</p>	<p><input type="checkbox"/> Yes <input type="checkbox"/> No Measurement:</p>		<p>604.8.1.1 Photo #:</p>	<ul style="list-style-type: none"> • Alter compartment
<p>3.42 If the door swings in, is the minimum required compartment area provided beyond the swing of the door (60 inches x 56 inches if water closet is wall hung or 59 inches if water closet is floor mounted)?</p>	<p><input type="checkbox"/> Yes <input type="checkbox"/> No Measurement:</p>		<p>604.8.1.1 Photo #:</p>	<ul style="list-style-type: none"> • Reverse door swing • Alter compartment

ADA Checklist for Readily Achievable Barrier Removal

Priority 4 – Additional Access

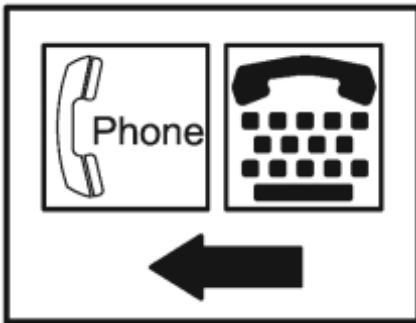

NOTE: *Alterations* to Qualified Historic Buildings and Facilities shall comply with the Florida Accessibility Code for Building Construction (FACBC) to the *maximum extent feasible*. All proposed changes to achieve *compliance* with the FACBC should be reviewed by the State Historic Preservation Officer (SHPO) prior to undertaking any required or suggested corrective measures described herein to avoid diminishing or destroying the historic significance of the Buildings or Facilities. There are exceptions to compliance with the FACBC for Qualified Historic Buildings and Facilities. Consult the SHPO for more information where indicated.

Project

Building

Location

Date



Surveyors



SHPO Contact Information :

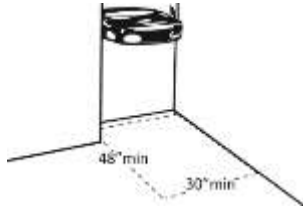
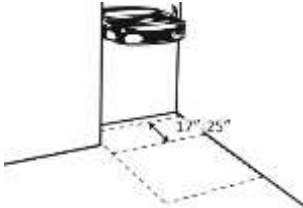
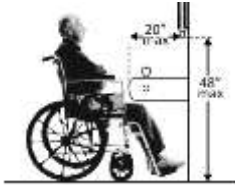

Florida Department of State
Division of Historical Resources, Bureau of Historic Preservation
500 South Bronough St.
Tallahassee, Florida 32399



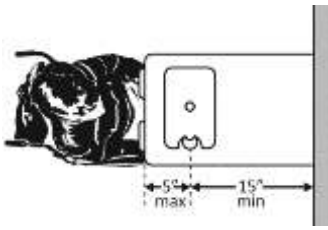
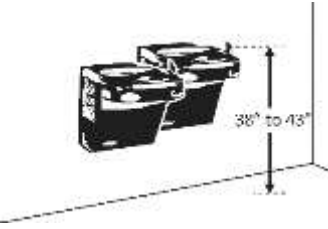

dos.myflorida.com/historical/preservation/architectural-services

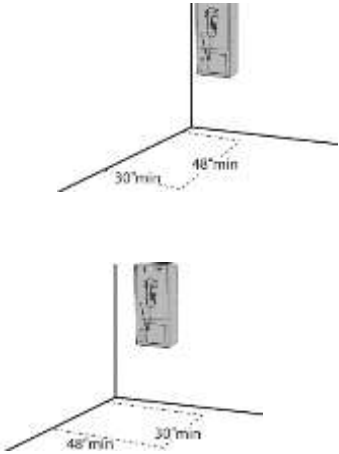

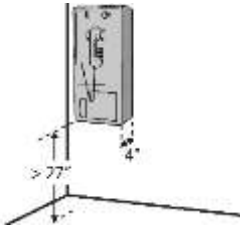
850.245.6333

Priority 4 – Additional Access		Code Requirements	2014 Florida Accessibility Code Section No.	Possible Solutions
Drinking Fountains				
<p>4.1 Does at least one drinking fountain have a clear floor space at least 30 inches wide x at least 48 inches long centered in front of it for a forward approach?*</p>	<input type="checkbox"/> Yes <input type="checkbox"/> No Measurement:		305, 602.2 Photo #:	<ul style="list-style-type: none"> • Alter space • Relocate drinking fountain • Install a drinking fountain in another location
<p>4.2 If there is a forward approach, do no less than 17 inches and no greater than 25 inches of the clear floor space extend under the drinking fountain?</p>	<input type="checkbox"/> Yes <input type="checkbox"/> No Measurement:		306.2 Photo #:	<ul style="list-style-type: none"> • Alter space • Replace drinking fountain
<p>4.3 If the drinking fountain is no deeper than 20 inches, are the operable parts no higher than 48 inches above the floor?</p>	<input type="checkbox"/> Yes <input type="checkbox"/> No Measurement:		308.2.2 Photo #:	<ul style="list-style-type: none"> • Adjust drinking fountain • Replace drinking fountain
<p>4.4 If the drinking fountain is no less than 20 inches and no greater than 25 inches deep, are the operable parts no higher than 44 inches above the floor?</p>	<input type="checkbox"/> Yes <input type="checkbox"/> No Measurement:		308.2.2 Photo #:	<ul style="list-style-type: none"> • Adjust drinking fountain • Replace drinking fountain

<p>4.5 Can the control be operated with one hand and without tight grasping, pinching or twisting of the wrist?</p> <p>Is the force required to activate the control no more than 5 pounds?</p>	<p><input type="checkbox"/> Yes <input type="checkbox"/> No</p> <p><input type="checkbox"/> Yes <input type="checkbox"/> No Measurement:</p>		<p>309.4</p> <p>Photo #:</p>	<ul style="list-style-type: none"> • Change control • Adjust control
<p>4.6 Is the spout outlet no higher than 36 inches above the floor?</p>	<p><input type="checkbox"/> Yes <input type="checkbox"/> No Measurement:</p>		<p>602.4</p> <p>Photo #:</p>	<ul style="list-style-type: none"> • Adjust drinking fountain • Replace drinking fountain
<p>4.7 Is the spout:</p> <p>At least 15 inches from the rear of the drinking fountain?</p> <p>No more than 5 inches from the front of the drinking fountain?</p>	<p><input type="checkbox"/> Yes <input type="checkbox"/> No Measurement:</p> <p><input type="checkbox"/> Yes <input type="checkbox"/> No Measurement:</p>		<p>602.5</p> <p>Photo #:</p>	<ul style="list-style-type: none"> • Adjust spout • Replace drinking fountain
<p>4.8 If there is more than one drinking fountain, is there at least one for standing persons?</p> <p>Is the spout outlet no lower than 38 inches and no higher than 43 inches above the floor?</p>	<p><input type="checkbox"/> Yes <input type="checkbox"/> No</p> <p><input type="checkbox"/> Yes <input type="checkbox"/> No Measurement:</p>		<p>602.7</p> <p>Photo #:</p>	<ul style="list-style-type: none"> • Adjust drinking fountain • Install new drinking fountain for standing height

<p>4.9 If the leading (bottom) edge of the fountain is higher than 27 inches above the floor, does the front of the fountain protrude no more than 4 inches into the circulation path?</p>	<p><input type="checkbox"/> Yes <input type="checkbox"/> No</p> <p>Measurement:</p>		<p>307.2</p> <p>Photo #:</p>	<ul style="list-style-type: none"> • Adjust drinking fountain • Replace drinking fountain • Add tactile warning such as permanent planter or partial walls
<p>Public Telephones</p>				
<p>4.10 Does at least one telephone have a clear floor space at least 30 inches wide x at least 48 inches long for a parallel or forward approach?</p>	<p><input type="checkbox"/> Yes <input type="checkbox"/> No</p>		<p>305.3, 704.2.1</p> <p>Photo #:</p>	<ul style="list-style-type: none"> • Move telephone • Install new telephone for clear floor space
<p>4.11 Is the highest operable part of the telephone no higher than 48 inches above the floor?</p>	<p><input type="checkbox"/> Yes <input type="checkbox"/> No</p> <p>Measurement:</p>		<p>308.2.1</p> <p>Photo #:</p>	<ul style="list-style-type: none"> • Adjust telephone
<p>4.12 If the leading (bottom) edge of the telephone is higher than 27 inches above the floor, does the front of the telephone protrude no more than 4 inches into the circulation path?</p>	<p><input type="checkbox"/> Yes <input type="checkbox"/> No</p> <p>Measurement:</p>		<p>307.2</p> <p>Photo #:</p>	<ul style="list-style-type: none"> • Adjust telephone

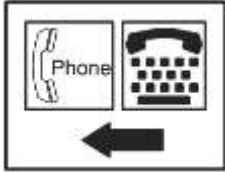
<p>4.13 Does at least one telephone have a volume control?</p>	<p><input type="checkbox"/> Yes <input type="checkbox"/> No</p>		<p>704.3</p> <p>Photo #:</p>	<ul style="list-style-type: none"> • Install volume control • Replace telephone with one that has volume control
<p>4.14 Is the volume control identified by a pictogram of a telephone handset with radiating sound waves?</p>	<p><input type="checkbox"/> Yes <input type="checkbox"/> No</p>		<p>703.7.2.3</p> <p>Photo #:</p>	<ul style="list-style-type: none"> • Add pictogram
<p>4.15 Does at least one telephone have a TTY?</p>	<p><input type="checkbox"/> Yes <input type="checkbox"/> No</p>		<p>704.4</p> <p>Photo #:</p>	<ul style="list-style-type: none"> • Install TTY
<p>4.16 Is the touch surface of the TTY keypad at least 34 inches above the floor?</p>	<p><input type="checkbox"/> Yes <input type="checkbox"/> No</p> <p>Measurement:</p>		<p>704.4.1</p> <p>Photo #:</p>	<ul style="list-style-type: none"> • If a seat is provided, TTY is not required to be 34 inches minimum above the floor • Adjust height of TTY
<p>4.17 Is the TTY identified by the International Symbol of TTY?</p>	<p><input type="checkbox"/> Yes <input type="checkbox"/> No</p>		<p>703.7.2.2</p> <p>Photo #:</p>	<ul style="list-style-type: none"> • Add symbol

<p>4.18 Do signs that provide direction to public telephones also provide direction to the TTY?</p>	<input type="checkbox"/> Yes <input type="checkbox"/> No		<p>216.9.2</p> <p>Photo #:</p>	<ul style="list-style-type: none"> • Add signs
<p>4.19 Do telephones that do not have a TTY provide direction to the TTY?</p>	<input type="checkbox"/> Yes <input type="checkbox"/> No		<p>216.9.2</p> <p>Photo #:</p>	<ul style="list-style-type: none"> • Add signs
<p>Fire Alarm Systems</p>				
<p>4.20 If there are fire alarm systems, do they have both flashing lights and audible signals?</p>	<input type="checkbox"/> Yes <input type="checkbox"/> No		<p>702.1</p> <p>Photo #:</p>	<ul style="list-style-type: none"> • Install audible and visual alarms